

# Documentation for Conservation

A manual for teaching Metric Survey Skills

# METRIC SURVEY

FOR HERITAGE DOCUMENTATION

# ACKNOWLEDGEMENTS

This resource was compiled as part of the RecorDIM Initiative, co-ordinated by Robin Letellier, to help resolve problems in the use of metric survey in conservation. The RecorDIM initiative is a joint goodwill alliance of practitioners, surveyors and conservators co chaired by Francois Leblanc (GCI), Giora Solar (ICOMOS) and Peter Waldhausl (CIPA) committed to improving the application of recording, documentation and information management in conservation. The material presented in this work has been compiled by Bill Blake and edited by Jon Bedford, surveyors at the Metric Survey Team, English Heritage who are grateful for the willing help of those who support the teaching of heritage documentation.

The preparation of this guide was made possible by the generous support of English Heritage and The Getty Conservation Institute in its active promotion of the RecorDIM initiative. The principal authors for the sections in the guide are:

Part 1	Introduction	Bill Blake Mario Santana Quintero
Part 2	Drawing	Bill Blake, Sarah Lunnnon
Part 3	EDM	Jon Bedford
Part 4	Rectified photography	David Andrews, Nick Becket
Part 5	Photogrammetry	David Andrews
Part 6	GPS	Bernard Thomason

The following have contributed to the content of this guide by making their practice, knowledge and skill available in support of the RecorDIM initiative:

*Getty Conservation Institute*

Francois LeBlanc,  
Rand Eppich

*Raymond Lemaire International Conservation Centre,;*

Koen Van Balen  
Mario Santana Quintero

*CIPA:*

Peter Waldhausl  
José Luis Lerma  
Fulvio Rinaudo

*ICOMOS Macedonia:*

Lazar Sumanov

*ICOMOS UK:*

John Hurd

*Michael Gallie & Partners:*

Pat Collins

*Plowman Craven & Associates Ltd.:*

Simon Barnes

Robert Chitham, Architect

*Leica Geosystems, UK:*

Hugh Anderson

*Abbey Halford Rowe Ltd.:*

Ray Jackson

*INTACH:*

Divay Gupta

*kubit gmbh*

Matthias Koch  
Klaus Kaiser

*I3Maniz:*

Wolfgang Böhler

*Heritage 3D:*

John Mills  
David Barber

*English Heritage :Metric Survey Team*

Paul Bryan  
Mick Clowes  
David Andrews  
Steve Tovey

Jon Bedford  
Andy Crispe  
Heather Papworth  
Kevin Leadingham  
Nick Beckett  
Colin Bamber  
Mike McGill  
Sarah Lunnnon

*English Heritage: Centre for Archaeology*

Tom Cromwell

*English Heritage :Technical Survey: Archaeology*

Bernard Thomason  
Trevor Pearson

*Latimer CAD Ltd.:*

Julie Edwards

This work is dedicated to the memory of:

† Robert W. Selwood      1938-2006 Dip Arch  
† Robin Letellier      1944-2007 RecorDIM co-ordinator

# PART I INTRODUCTION



# INTRODUCTION TO METRIC SURVEY FOR HERITAGE DOCUMENTATION

This resource is a teaching aid for the application and procurement of metric survey (sometimes referred to as measured survey) for heritage documentation. The document is focussed on the application of these techniques to built heritage, although metric survey techniques are successfully applied elsewhere.

The metric survey techniques covered in this resource are:

1. INTRODUCTION & KEY CONCEPTS
2. DRAWING
3. INSTRUMENT (EDM) SURVEY
4. RECTIFIED PHOTOGRAPHY
5. PHOTOGRAMMETRY
6. GPS

The aim is to provide a base resource for those who need material to teach the application of metric survey techniques in heritage conservation.

## METRIC SURVEY TECHNIQUES

Metric survey is the use of precise and repeatable measurement methods to capture spatial information. The acquisition of the right survey for the right cost at the right time is a process that requires an appreciation of the balance between the three key elements of the survey process:

- ◆ MEASUREMENT
- ◆ SELECTION
- ◆ COMMUNICATION /PRESENTATION

The interaction between the surveyor and the subject of the survey is a process that influences the information

we collect from the historic environment. In metric survey this process is typically controlled by a brief and specification rather than by the inquiry driven concerns of thematic investigators. The surveying of our heritage estate is a crucial part of our curatorial role in caring for it.

Metric survey forms the base map upon which our conservation actions are recorded and planned; by mapping the historic environment it can be managed, conserved, and enjoyed. Just as an unfamiliar journey is best begun with a map, so the understanding needed to exercise our responsibility to conserve is best founded on a metric basis. 'Metric survey' is the term used internationally (CIPA, Böhler et al, 1997) to describe the application of precise, reliable and repeatable methods of measurement for heritage documentation. It is different from investigative processes which use the term survey to describe a method of inquiry. Survey in general, and metric survey in particular, follows conventions that influence the selection and presentation of measured data. For example, the concepts of plan, section and elevation have been inherited from the 2D conventions of the architectural practise and the development of new methods of 3D data capture has put these conventions under some stress. It is hoped that the examples shown here will reinforce the necessity of respecting the conventions that have served architecture so well for the optimum transmission of information.

## THE CONSERVATION CYCLE & HERITAGE DOCUMENTATION

Heritage documentation and understanding are an integral part of the conservation process. The conservation process can be seen as a four-step cycle, each step informing the next. The basic premise of the conservation cycle is that to successfully manage and conserve the historic environment it must be understood. Heritage documentation is essential because it provides the data for recording condition, understanding, interpretation and action.

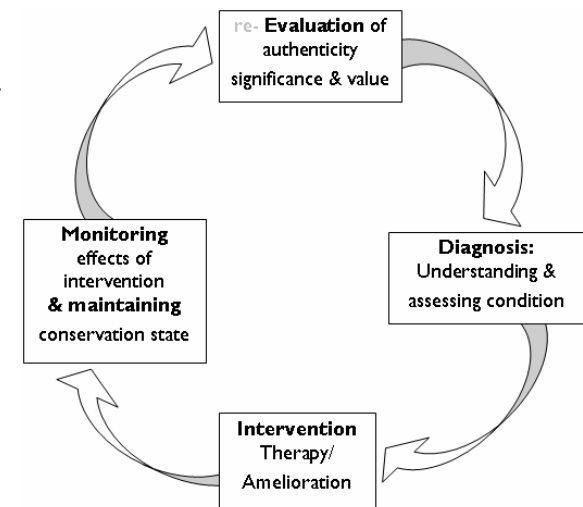

Fig 1.1 The conservation cycle. After K. Van Balen

**TYPES OF METRIC SURVEY** Metric survey techniques can be divided into two groups: *indirect* and *direct*.

**INDIRECT TECHNIQUES** (such as photogrammetry and Laser scanning) are used when there is a need for undifferentiated metric data OR when the size of the subject and its scale of representation require a high density of point capture.

**DIRECT TECHNIQUES** (such as EDM, GPS and drawing) where interpretation and selection are made at the point of capture are useful where the expertise of a user is incisive to the outcome of data collection. Direct techniques like EDM and GPS survey rely on the surveyor understanding the extent and depiction of the subject to be mapped at the time of survey.

**HERITAGE DOCUMENTATION** is a continuous process enabling the monitoring, maintenance and understanding needed for conservation by the supply of appropriate and timely information. Documentation is both the product and action of meeting the information needs of heritage management. It makes available a range of tangible and intangible resources, such as metric, narrative, thematic and societal records of cultural heritage. Survey is a key aspect of heritage documentation as recognised by the ICOMOS general assembly at Sophia in 1996: 'Recording is the capture of information which describes the physical configuration, condition and use of monuments, groups of buildings and

sites, at points in time and it is an essential part of the conservation process.'

**THE VENICE CHARTER** of 1964 states: Article 16. 'In all works of preservation, restoration or excavation, there should always be precise documentation in the form of analytical and critical reports, illustrated with drawings and photographs. Every stage of the work of clearing, consolidation, rearrangement and integration, as well as technical and formal features identified during the course of the work, should be included. This record should be placed in the archives of a public institution and made available to research workers. It is recommended that the report should be published.'

This is a refinement of the obligation to ensure documentation as an active part of works to historic fabric as expressed in the Venice Charter. The needs of the conservation cycle will require re-examination of the metric record at the monitoring and re-evaluation stages. This means metric survey must be archived in anticipation of future uses beyond the immediate. Digital data sets, despite all their advantages, are vulnerable to improper storage environments, system dependence and format compatibility. Therefore the brief for the survey needs to address not only immediate but also long term data requirements to maximise its life and utility.

**ANTE-DISASTER RECORDING** The power of the image as a documentary resource is well understood.

What is less well known is that metric imagery has a great value for the reinstatement of lost spatial information. Since the pioneering work of the Prussian architect Albrecht Meydenbauer in the late 1850s there has been no dispute over the merit of the controlled stereo-photograph as a primary ante-disaster tool: the restitution of displaced material by anastylis is massively improved with the use of ante-disaster stereo records. The acquisition of ante-disaster data sets has long-term benefits that cannot be overlooked when making assessments of risk to valuable and irreplaceable historic fabric.

## WHY USE METRIC SURVEY?

Man's memory is not perfect; man's perception is not perfect. Detecting change and informing actions is rarely possible without measurement or precise information. When faced with the necessity to document our historic estate the focus must be on meeting the needs of research, analysis and conservation. A good set of sketches, photographs and a written description are all vital to understanding a structure or site: opinions can be formed, theories tested and diagnostic details recorded, all without measurement. It is when the components of a conservation team need to work together that a common metric data set is needed and measurement thus becomes the link in the

conservation cycle. The conservation process requires information at all stages: metric survey has the advantage over non-metric information in that it can be re-used at each stage. A good example of this would be a photogrammetric survey that is acquired in the evaluation phase. It may be subsequently plotted for mapping condition and active erosion sites, later used for façade repair scheduling, then archived and inspected as a pre-intervention record. Metric information is one kind of information needed by the cycle: understanding the

significance, condition and interventions required is a team task that demands the cooperation of specialists to be effective. Metric survey is one of many tools to be used in organising knowledge in the conservation of heritage places.

See also: *Understanding Historic Buildings: Principles of Good Recording Practice*, English Heritage, 2005; *Informed Conservation 7.3.2 p77* Clark, K, English Heritage 2001. ISBN 1 873592 64 7

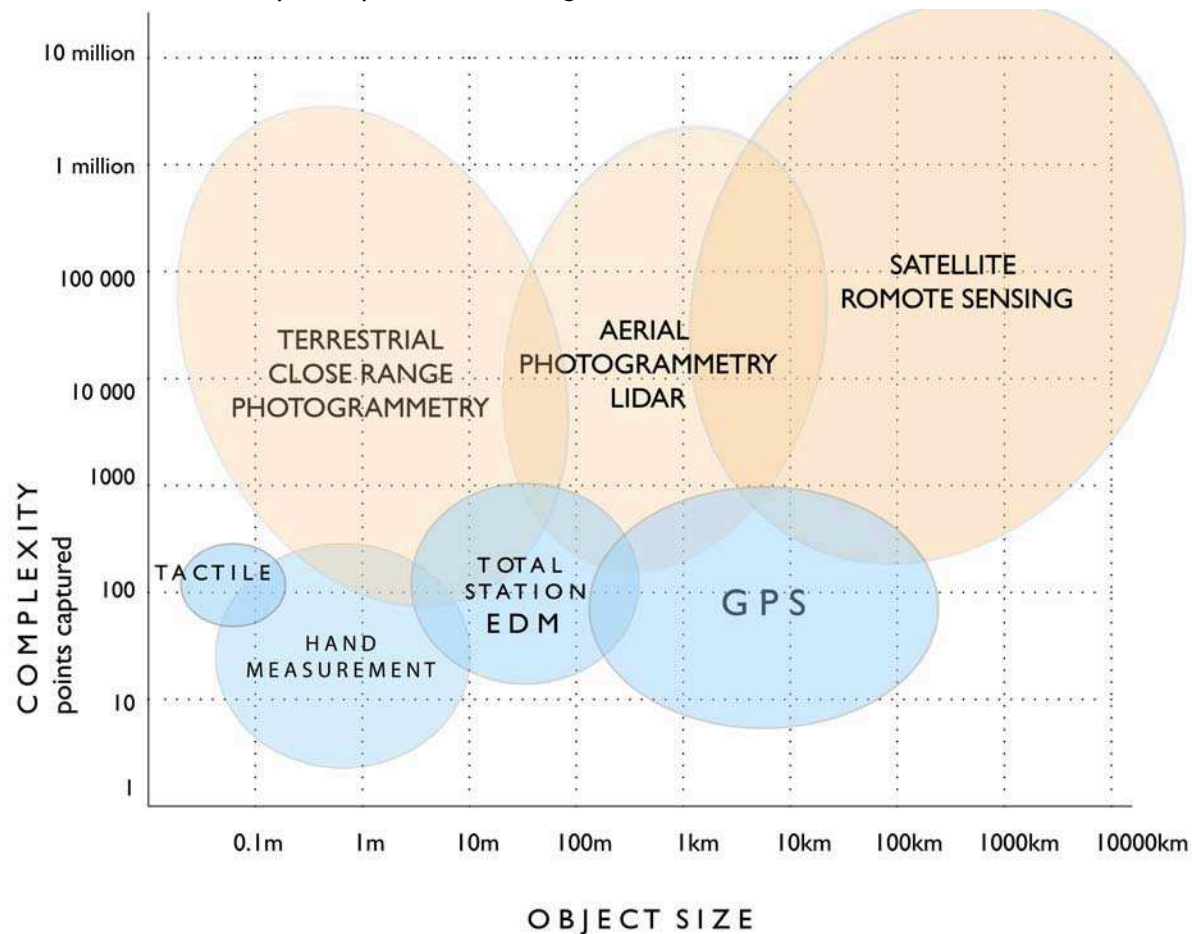

To use an appropriate technique it is essential to understand its performance, its required end use, the precision expected and the resources available. There is no simple formula that will determine which survey technique should be used where, however there is a relationship between the scale required, the selection of data and the desired output. If the object is small and relatively few points need to be recorded to describe it (e.g. a single block or brick) it can be measured by hand, but for the entire façade of a building an effective mass capture method would be more appropriate. Simple measurement methods are not likely to be suitable if objects are large, complicated or require multi-purpose data sets in a short time span. Fig 1.2 illustrates the disposition of metric techniques by scale and point density and Fig 1.4 highlights their common uses. Ultimately the suitable application of technique is based on a balance between the end use of the survey and the availability of skills, resources and time.

#### METRIC METHODS FOR DOCUMENTATION

The vertical scale in Fig 1.2 represents the number of points captured by the survey method: this is an indication of the object complexity that can be captured. The shading indicates the method type: Blue denotes direct techniques, while Orange denotes indirect techniques. Note the overlap areas, which show that there is an alternative

Fig 1.2. Comparison of survey techniques for Heritage Documentation. by kind permission of Dr. Wolfgang Böhler

application between direct and indirect techniques. Despite the obvious performance of indirect techniques it should be borne in mind that a specific end product may well require a selection and presentation process that must be defined.

### INTEGRATION OF TECHNIQUES

The metric record of built heritage in particular requires a combination of techniques to be successful: a site drawing combined with the robust precision of, for example, photogrammetry generates data with both architectural sensitivity and metric performance: a must when our data is transmitted in CAD for manifold uses. In anticipation of the integration of metric data with other data sources it is a wise investment to develop the CAD skills to handle this process.

### THE SURVEY BRIEF

The desired outcome of a project can only be controlled by the skill of the surveyor and the surveyor's understanding of the requirements of the survey. Unless the surveyor is familiar with the requirements of the project some indication of the selection criteria and presentation requirements expected is essential. For those who commission surveys, the brief and specification are all that guide the survey to the goal of the right documentation for the conservator. Preparing the brief in the knowledge of what survey can deliver is far better than appointing a surveyor and 'hoping for the best'!



*Fig 1.3 Undifferentiated and differentiated data. The orthophotograph (top) shows the power of undifferentiated capture by an indirect method: aerial photography which has rapidly revealed the nature of the site including, building types, roof configurations, land use, how the buildings are linked, their materials and condition. The measured plan of the buildings (bottom) tells a different story, resolvable to large scale (1:50) the building plans show the internal spaces, wall thicknesses and openings that will inform the re-use planned for consolidating the site. The differentiation in the building plans is the information has been SELECTED at capture for the purpose of building conservation.*

## SUMMARY TABLE OF METRIC SURVEY TECHNIQUES

TECHNIQUE                      PRODUCT                      TYPICAL APPLICATION                      SUBJECT SIZE                      CONSTRAINTS ON USE

### INDIRECT TECHNIQUES: UNDIFFERENTIATED DATA AT CAPTURE:

REMOTE SENSING	3D	Wide area landscape records	Landscape monitoring, water content, mineral reflectance and vegetation health mapping etc.	1-1500Km <sup>2</sup>	Dependant on wave band, will not resolved down to centimetric precision in most cases.
AIRBORNE LASER SCANNING	3D	Topographic mapping	Landscape mapping and monitoring	1-500Km <sup>2</sup>	Post spacing at sub-metre resolution is costly.
AERIAL PHOTOGRAMMETRY	3D				Co-ordinated flight plan and ground control.
TERRESTRIAL LASER SCANNING	3D	Point clouds, Surface models	Building models and drawings	5-500m <sup>3</sup>	Point density must be matched to required information outcome. Congruent image capture needed.
CLOSE RANGE PHOTOGRAMMETRY	3D	Photo-maps, CAD drawings, ante-disaster records	Architectural façade drawings, Orthophotos, stereo pairs, surface models,	2-100m <sup>3</sup>	Calibrated camera, optimised image capture, object area control, processing software and operator skill.
RECTIFIED PHOTOGRAPHY	2D	Condition records	Records of flat facades	2-50m <sup>2</sup>	Only single reference plane scalable.
ARTEFACT SCANNER	3D	Point-clouds, surface models	Sculpture relief carving etc	1-5m <sup>3</sup>	Controlled environment required.

### DIRECT TECHNIQUES: DATA SELECTED AT CAPTURE:

G P S	3D	Topographic mapping, point data	Landscape surveys, inventory mapping primary orientation to global co-ordinate system	1-20Km <sup>2</sup>	Open sky needed. Height precision can be a problem.
TOTAL STATION/ E D M	3D	CAD wire-frames, Point data	Topographic mapping, Building plans & sections. Precise control networks measurements	0.5-50m <sup>3</sup>	Data organisation is needed by code, layer or GIS protocol, trained operators are required.
LEVELLING	2D	Discrete point height monitoring	Precise height points	1-50m	Structural engineers selected diagnostic points measured for movement monitoring.
DRAWING	2D	Key detail records, explanatory diagrams	Structural notes, architectural definition, excavation records	0.25-5m <sup>3</sup>	Selection of information based on subjective domain knowledge.

Fig 1.4 The procurement of metric survey requires the identification of the appropriate technique or performance required to meet the documentation need. The provision of a given metric data set must be governed by a brief, a specification and a project design that considers metric survey requirements at an early stage to avoid duplication and the errors concomitant with repeated localised provision. (Table adapted and derived from Santana Quintero, M: The use of 3D techniques of documentation and dissemination in studying of built heritage: KU Leuven 2003)



## HERITAGE DOCUMENTATION.

Documentation is both the product and action of meeting the information needs of heritage management. Heritage documentation comprises the capture of (recording) information about heritage places and its management and dissemination. Metric survey is specifically concerned with measured spatial data.

## FIT FOR PURPOSE

The end uses of survey are diverse: e.g: monitoring, project-planning, stylistic analysis, ante-disaster, condition record, intervention planning, etc. The correct decision on the method of data capture is essential for its optimum use. The data MUST enable the purpose.

## 3D and 2D

3D capture is rarely more costly than 2D but historically recorded information has used 2D media. The presentation of 3D information as 2D is a form of abstraction that drives many graphical conventions and standards. The cost (in terms of skill and processing power) of maintaining 3D data integrity and 2D presentation standards is greater than working in either solely 2D or 3D. Consideration of the value of 3D information should be balanced against the cost of managing 3D work environments.

Fig 1.5 Accuracy and precision of shots at a target.  
Left: high precision, low accuracy. Right: high accuracy, low precision.

## SURVEY CONVENTIONS

Survey presents measured information in different ways but there are a number of common concepts, principally from mapping (scale, precision, accuracy, projection control, detail etc), that should be understood when considering metric documentation:

## SCALE

When measured data is transmitted it is usually shown as a scaled representation of that which was surveyed. It is a common misconception that when survey data is viewed in a CAD system it is 'scale free'. This can never be the case because the information contained is necessarily an abstraction (i.e. a simplified form) from the real world: its very purpose is to transmit accessible information. Building surveys (with the important exception of setting-out data) are never presented at a scale of 1 to 1. It is often offered as an example of a maximum attainable precision but this is never the case, due to the selection of depicted information. 1 to 1 can be used for details but 'full size' is a better description, as the idea of the 'drawing as replica' is avoided.



## PRECISION, TOLERANCE & ACCURACY

In surveying it is common to use the terms accuracy and precision to describe the performance of data: it is important to make the distinction between the performance of a measurement system and the performance of a survey as a whole. When working with metric data the performance of both the method used and the constraints of its provenance should be understood, as the purpose of a survey can reveal as much about the selection and presentational criteria used as the method of measurement.

- ◆ *Precision* characterises the degree of mutual agreement or repeatability among a series of individual measurements, values, or results. The precision of measurement is a function of both the definable precision of the object being measured and the measurement technique used. e.g.: (Fig1.5 Left) If an object is measured several times, by different operators, using the same technique and the differences recorded and the same procedure is repeated with a different object the variation in object precision and measurement performance can be assessed.
- ◆ The *tolerance* is an indicator of the performance of a measurement technique over a sample of measurements e.g.: the maximum difference allowed when testing

could be 95% or 99.7% or 100%. A mean square error, the normal indication of accuracy, corresponds to a 68% level.

- ◆ A test of the *accuracy* of survey work describes how near a single recorded value is to the 'true' value or the degree of conformity of a measured or calculated quantity to an actual, standard, nominal or absolute value. (Fig 1.5 Right)

The order of accuracy may be determined as: *relative*: where comparison to an internal reference is used, *absolute*: where a reference value is known with certainty, *nominal*: where an average is used as the reference, *inner*: where the measurement system alone is described, *outer*: where procedural factors are included.

Great care should be taken when using the terms precision and accuracy: it is wise to carefully identify and qualify specific aspects of survey work when using them. If a survey is required to be precise and accurate it is better to say why and how it should be so than simply state the word!

**PROJECTION: PLAN, SECTION & ELEVATION**  
Measurement alone is not enough to describe the world around us. A projection is any method used in map making to represent a three-dimensional surface on a plane. In map making the projection is used to deal with the curvature of the earth (it is very important in

techniques like GPS surveying.) For small sites and building surveys projection is used to get the required view of the subject in a form that can be readily scaled. Architectural drawings use a 'square on' or orthographic projection to achieve the commonly used views: *plan*, *section* and *elevation* which comprise the primary architectural drawing set. In working drawings they describe the way buildings are assembled and the materials they are made from. In design and presentation drawings they can be used to illustrate concepts and the relationships between spaces.

**Plan** is similar to a conventional 'map' of a space (created by a plane cutting horizontally through a space) and is a downward looking view of the building with the walls cut horizontally at an agreed height (usually between the waist and shoulder) to show the features of the building as functional openings determined by their use.

A **section** is a vertical cut through a building to show its internal spaces as projected onto a vertical plane, much like the sliced surface of a loaf of bread. Sections may also show the revealed inner elevations of the building (known as *sectional elevations*).

**Elevation** commonly describes a drawing of an exterior of a structure or building as if seen from straight-on. An *elevation* is the projected view of a building façade which may show single or multiple planes depending on the

desired content of the view. The plane for an elevation is always vertical.

#### RECONNAISSANCE

Familiarity with the site, the purpose of the survey, its conditions and constraints is an essential part of planning any survey. The better informed the surveyor the better the outcome.

#### CONTROL

Survey requires a network of fixed points at a high order of accuracy so that detail measurements derived from it will be consistently precise. The preparation of rigorous control data is a costly but essential part of the survey process. Any proposal for survey should include a description of the control technique proposed and its expected accuracy.

#### DETAIL

The drawing of details defines the quality of the record and involves understanding both its delineation and the scale at which it will be depicted. Knowing which parts of the survey require detailing and why is key to effective data integration. Construction details often determine building character, so special attention should be given to both the exploration of the hidden spaces of a building and its type, materials and construction.

# BALANCING MEASUREMENT SELECTION & PRESENTATION

## PRINCIPLES OF VERIFIABLE SURVEY

### There are 3 basic principles guiding survey:

- 1 'No action without control' Survey should not be conducted without consideration of how the parts will fit together.
- 2 'Work from the whole to the part.' Establish the geometry of the widest area of interest before tackling detail in a small area.
- 3 'Match the order of precision and scale to the time and resources available' Survey is constrained by the scale of the required outputs and the costs of both capture and presentation.

Survey procedures are characterised by:

- ◆ *Systematic* data logging and processing, the independent check.
- ◆ *Repeatability*: principle of metric process that measurement cannot be unique to a given record but can be shown to be achieved by others using similar techniques with similar results.
- ◆ *Verification*: the retention of raw un-processed measurement data and its work path as demonstration or proof of survey.
- ◆ *Reversibility*: If a procedure can be reversed could the survey be recovered from the raw data?
- ◆ *Data Provenance*: If a survey is reliant on unique expertise (e.g. for the selection of lines on a plot) the qualification and experience that guarantees that domain knowledge should be declared in the method statement and declared in the authorship of the work.

## UNDIFFERENTIATED DATA COLLECTION:

The primary data sets from indirect techniques (e.g. photogrammetry, laser scanning) are largely free of data differentiation other than that imposed by the constraints of the capture method itself. As undifferentiated data the products of indirect techniques may need to be processed, and it is in this post-capture phase that the selection and presentation of information needs to be controlled either by brief and specification or by the applied expertise of operators.

## DATA SELECTION AT CAPTURE.

Direct techniques (e.g. EDM, GPS, drawing) maximise the expertise of a specialist at the point of data capture. The selection of information can be driven by a wide spectrum of survey purposes. While the impact of the expertise can accelerate the data capture phase it must be balanced against the single use data out come. Using data derived from direct techniques requires a detailed understanding of the purpose behind the survey and its commissioned constraints.

## SKILLS & UNDERSTANDING.

Those who undertake the measured survey of heritage places need the requisite skills. The suitable application of direct techniques and the production of a survey 'fit for purpose' is more effective when an understanding of the building, its construction techniques and materials is applied. Direct techniques are often influenced by contact with historic fabric during the measurement

process. Indirect techniques provide mass data capture within a time-scale unmatched by direct techniques and the failure to deploy such techniques when appropriate may result in an unnecessarily high expenditure of time and money.

## INTEGRATION OF SURVEY DATA

It should be remembered that few buildings are surveyed using a single technique. A number of techniques, both direct and indirect, are commonly deployed and the data integrated to obtain a complete survey. The integration of data from different sources relies on a system of common control being used and, usually, CAD as the data integration platform.

## BALANCING MEASUREMENT, SELECTION & COMMUNICATION

Getting the right survey to meet the needs of heritage documentation takes more than selecting the appropriate survey product. Management of the selection and presentation of survey through training, brief and specification is needed to make the best use of the survey tools at our disposal. The communication of captured information to agreed standards requires an understanding of the appropriate conventions. Many surveys, despite excellent metric performance, fail because the client has expected a particular method of depiction of a given subject and cannot use the

survey for its intended purpose. The balance between precision, cost and time when applying metric technologies to heritage documentation should be considered carefully when commissioning survey. If the technique deployed is inappropriate the project will suffer either through inadequate data or through the extra costs of repeating the survey tasks. Successful documentation depends on the interaction of the principal specialists involved: if the survey is driven by a clear understanding of its purpose it will form a sound basis for conservation action; it must therefore be informative, accessible and legible!

**DIRECT TECHNIQUES** need clear guidance on the selection of information for the specified purpose of the survey, either by careful briefing or from the surveyor's knowledge and understanding of both the subject and purpose of the survey. The presentation of the measured data needs to conform to the expected norms and conventions of the project, be it conservation, thematic or interpretative documentation.

**INDIRECT TECHNIQUES** need careful planning to maximise their benefit. The purpose of data acquisition must be apparent to all in the information-processing path from capture to presentation. The technical constraints of indirect techniques must be understood when choosing methods. The ante-disaster performance of indirect techniques is compromised if recorders fail to understand the significance and value of the subject.

*Fig 1.6 Plan of roof rafters showing racking:  
The selection of information shown on this survey is crucial to its performance as both a record and a basis for marking up proposed work. The use of a direct method has allowed only the required information to be captured. Indirect methods would have involved grater expense abut world perform better over a greater time span as both ante-disaster and state of conservation records.*

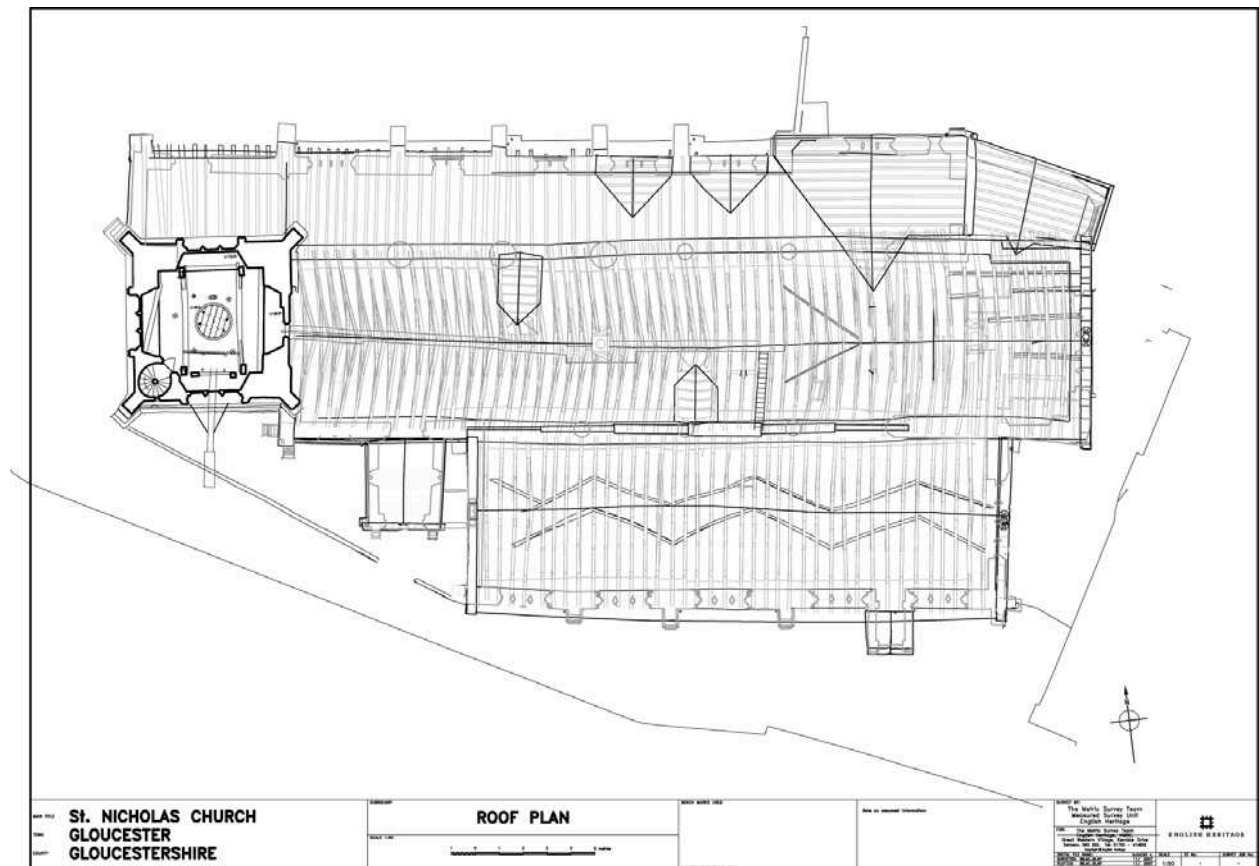

PART 2 DRAWING

2

This part of the guide has been prepared to help those who want to know more about drawing as a key tool in heritage documentation. We all have an innate ability to draw, as can be seen when we sketch out directions to a familiar destination when asked. What we lack is practice and an understanding of the rules of what we draw; all drawings express an idea and it is this that makes drawing a natural human action. The purpose of drawing is to convey a visual record and its role in recording our heritage has a deep and vital history: our very perception of the ancient world is influenced forever by its first interpreters and their drawings.

#### DRAWING IS A KEY PROCESS

Drawing is integral to the successful outcome of many heritage-recording projects. It is an incisive technique as it uses the selection and transmission of information in a single action. The process of selection in drawing uniquely expresses intelligence and understanding. As drawing is personal and subjective it is sometimes perceived as 'un-scientific' and outside the digital workflow, this is quite wrong and is an opinion born out of ignorance of both the historic power of the image and the essential qualities demanded by heritage records!

#### MATCHING DRAWINGS TO NEEDS

Archaeological drawings produce rich information that is valuable for contextual analysis but may not meet the needs of an engineer or architect. The filter of selection needs to be matched to the specific end use of the

drawing: the better informed the draughtsperson the better the drawing will be! There is no one fixed way of getting a drawing done, therefore matching the method to the problem will involve making use of a variety of techniques. When repeatability of metric scale is required, then metric control, like a grid, is needed. When all that's needed is a sketch to show, for example, how a purlin fits to a rafter the drawing must show the functional surfaces and the workings of the joint rather than record at scale in the manner of a direct plot.

#### PHOTOGRAPHY & DRAWING

*Photograph what you cannot draw and draw what you cannot photograph* is an adage born out of recording experience. A photograph will support a drawing and vice-versa. Photography is a kind of safety net that can be used as an *aide-memoire* and should reinforce the observation used for drawing. Drawing, like all recording methods, works best in conjunction with other techniques like, photography, which complements drawing well by recording colour, texture and undifferentiated form.

#### A UNIVERSAL MEANS OF COMMUNICATION

Drawings can reveal the hidden and explain the relationships between components (Fig 2.1): the cutaways, call-outs and exploded details are typical devices that we read as part of our visual vocabulary. We take our ability to read drawings for granted but the successful communication of information takes skill and planning to be effective.

This drawing (fig 2.1) is not only an example of a clear diagram, but it forms part of the standard used for wood-working terms in British Standard No. 565 (used with permission), an example of how drawings can convey standards as well as understanding.

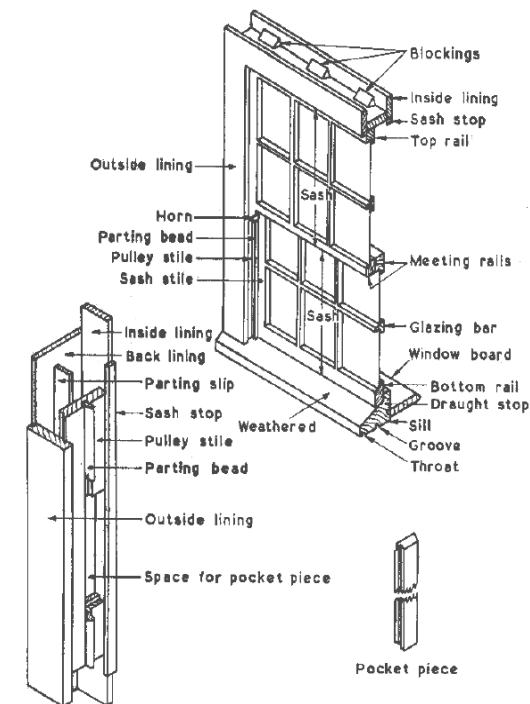

Fig 2.1 Illustration showing the standard names of components of a sash window (BS 565: 1963).

## THE 3 TYPES OF DRAWING

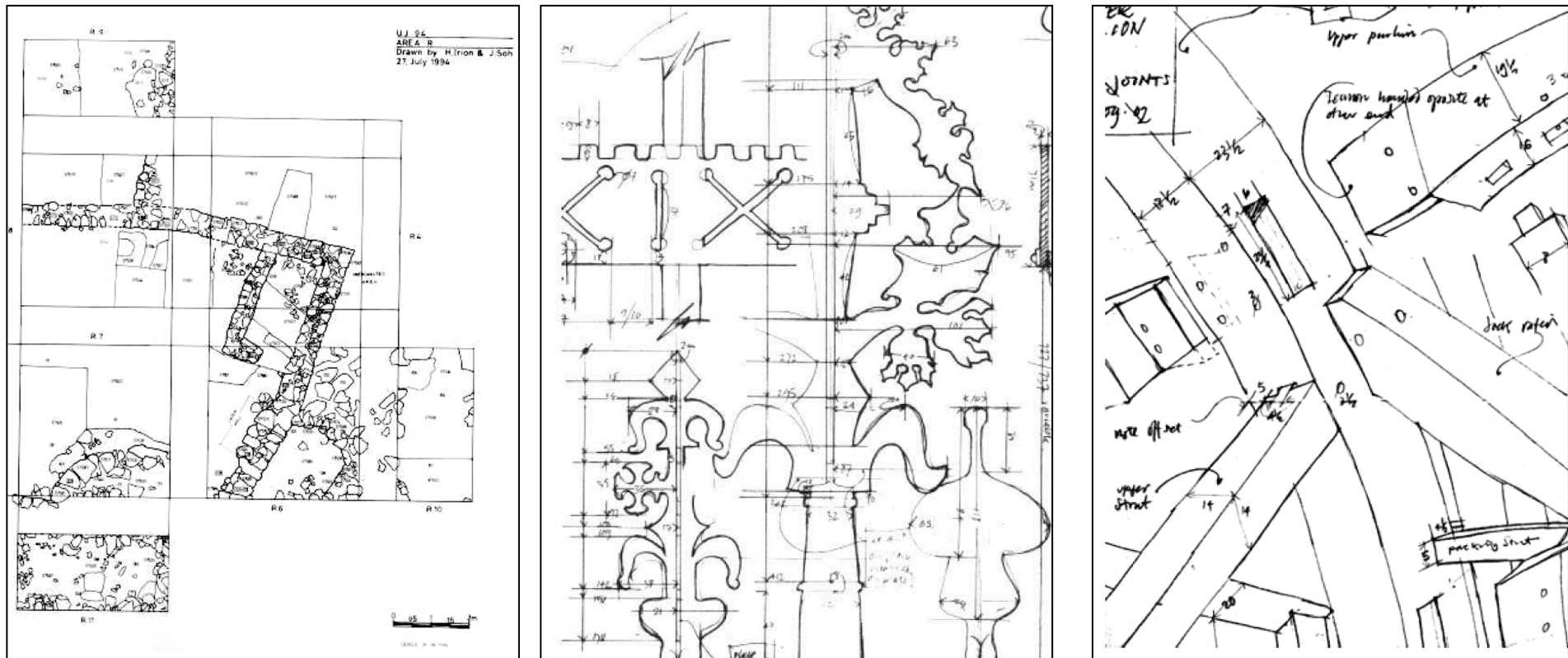

Fig 2.2 Examples of the 3 main types of drawing  
 Above: **DIRECT PLOT:** part of an excavation plan plotted onto gridded drafting film at 1:20 scale.  
 Centre: **MEASURED DRAWING:** the drawing, showing railing detail, uses running measurements.  
 Right: **SKETCH DIAGRAM:** prepared in support of 3D wireframe from REDM for measurements, referenced to a plumb line and insets to show detail for the construction of a CAD model of the timber structure supporting a leaded dome.

### 1. DIRECTLY PLOTTED DRAWINGS

Drawings made by plotting to scale on site are also known as *direct plots*, are usually as a primary record. The site plot is then traced into CAD or 'worked up' as a fair copy for archive record. Generating the scale plot on site, although time consuming, produces the most metrically reliable results provided the control used ensures the precise fit of each individual section to the

overall drawing. Direct plots are typically used for 1:20 and 1:10 scale drawings of building elevations, trench profiles in archaeological investigations and also for the plotting of underwater archaeological remains. As a method it is robust and has the virtue of being self-checking: as the drawing progresses the plot can be tested for its fit to the subject.

## 2. MEASURED DRAWING

Sometimes known as *dimensioned sketches*, measured drawings are the classic method of conducting architectural surveys. The method relies on a good clear sketch of the subject being annotated with the dimensions used to replicate the geometry at scale. This is a technique that can be fraught with risk as it's easy to miss measurements. Measured drawing practitioners usually have a strong type-specific knowledge: if there is a failure of understanding, the drawing will be deficient and a return to site will be needed. The great strengths of the technique are the speed of capture and the expression of the draughtsperson's expertise.

Fig 2.3 Surveyors notebook and CAD model

The nose width, winder chord and riser heights of the stairs are booked against the step number in the chain book, starting at the base. Thumbnail sketches show non-standard details of landing and displacements as required. This is rapid and selective work; this draughtsman will plot from his own notes and uses his own shorthand to interpret the measurements. A systematic tabulation has been adapted with sketches in anticipation of 3D modelling. This survey was controlled by 3D wire-frame traced off the building directly into CAD using TheoLt as it was judged faster to draw details than try to develop the wire-frame in CAD on site. The 3D wire-frame from REDM (Reflector-less EDM) provided an armature on which to 'hang' the measurements in CAD and allow profiles to be solid modelled in 3D. The model was developed to allow multiple views of the staircase in situ as a component in sectional elevations and plans in advance of intervention.

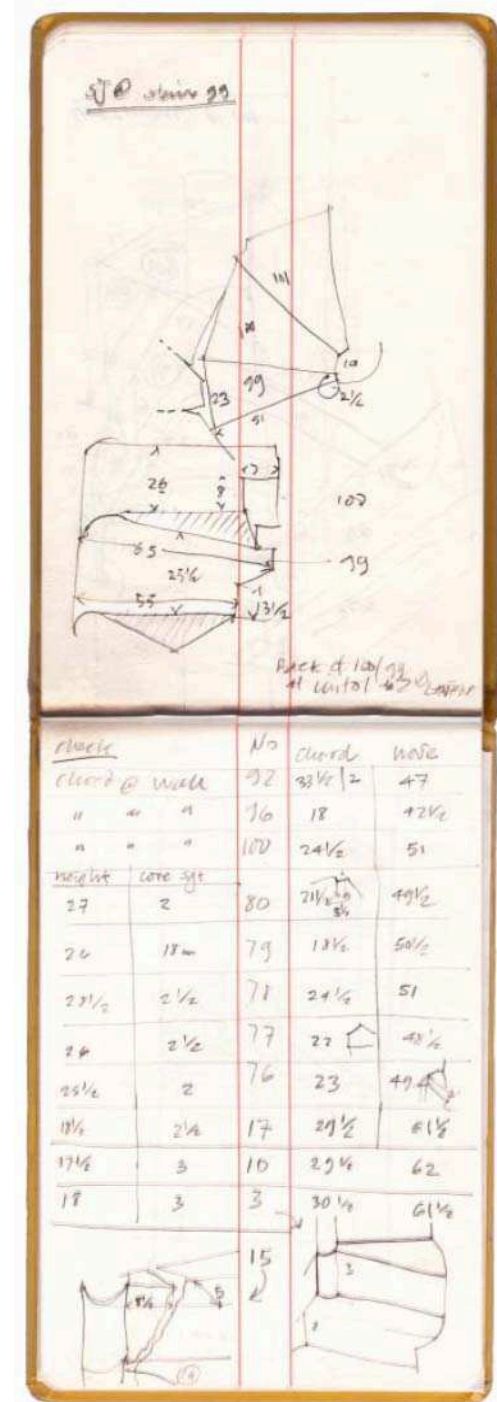
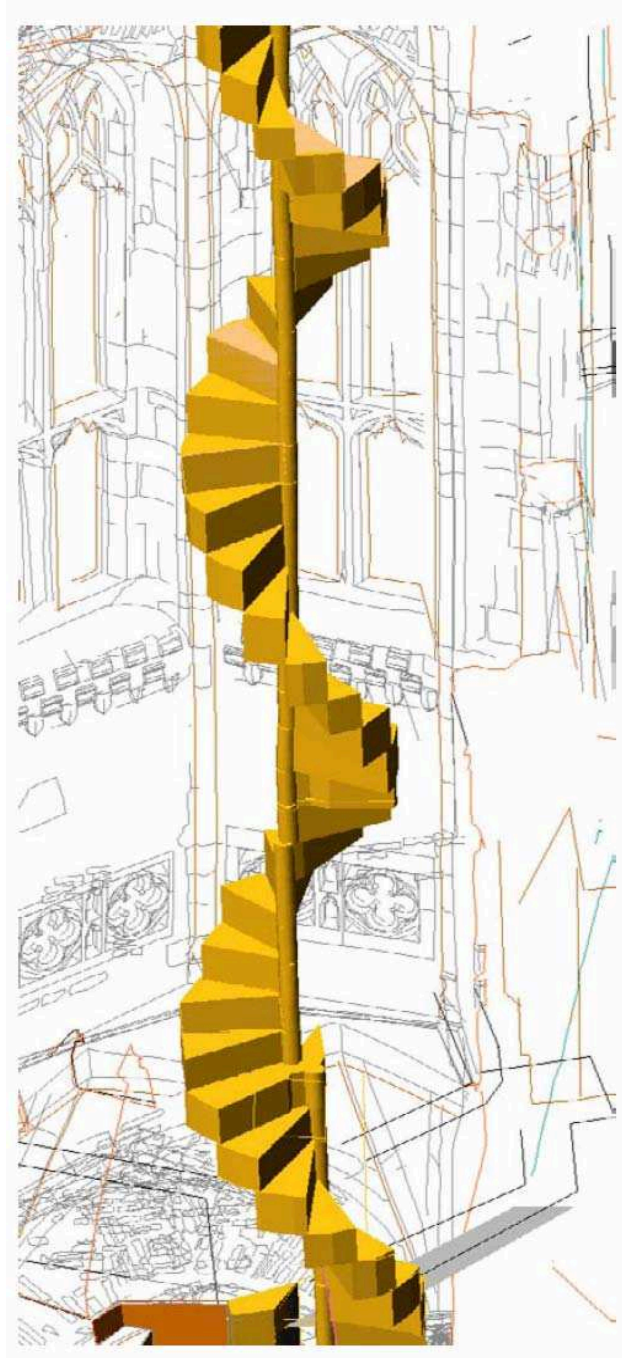



### 3. SKETCH DIAGRAMS

A sketch diagram is a diagnostic drawing that allows understanding of the subject to be transmitted. The sketch shows the key relationships between components, the match or otherwise of prototypes and the explanation of that which is not apparent from photography. In short the sketch diagram is the 'x-ray vision' of the documentation process.



### WHEN TO DRAW

Drawing should be used wherever there is a need to record information that isn't captured by other techniques. Preparing a drawing takes time and concentration, so selecting what to draw needs both care and a clear understanding of how the drawing will contribute to the aims of the project. While measured drawing can be used as a stand-alone survey technique, it is most effective as a method for completing data from other sources. It is most commonly employed in areas where:

- ◆ photogrammetric plots are incomplete
- ◆ infill to CAD wire-frames is required
- ◆ edges in point clouds need definition
- ◆ 3D modelling requires delineation of edges and hidden detail
- ◆ a thematic layer is to be added to base data
- ◆ access is limited for survey instruments
- ◆ lighting is poor for photography or the definition in a photo won't reveal the required profile or detail
- ◆ there is a requirement to apply type-specific knowledge to record architectural detail

### DRAWING AND OBSERVATION

The observation required for drawing engages the surveyor in a dialogue with the building. In making the selection of details to be drawn and selecting the lines to record them, the surveyor will be testing the fit of patterns and seeking the forms that define the architecture.

*Fig 2.4: Sketch Diagram of a capital of the nave arcade, Inglesham, Gloucestershire. The survey required a CAD drawing for a sectional elevation. Due to multiple surface reflectance the REDM trace failed to delineate the details. The drawing clarifies the data.*

### MATERIALS

The drawing should be executed on an archival medium and with an appropriate weight of drawing lead. Anticipation of corrections and making the drawing 'work' in terms of layout and annotation are important.

### MEASUREMENT METHODS

There are two main manual methods of measuring: chain & offset and Braced diagonals (sometimes known as taped triangulation or intersection) **Chain and offset.** The chain line and its offsets can be shown on the drawing or tabulated elsewhere; the drawing must show the start and end of the chain line and where the offsets are booked. (See Glossary) **Braced diagonals** or intersection Involves measuring the diagonals of a room and the wall lengths that close triangles is a classic triangulation technique that needs clear and systematic annotation on the drawing (Fig 2.9).

### DRAWING ARCHITECTURAL DETAIL FOR ELEVATIONAL PROJECTION

The decorated capital was sketched to enhance an REDM trace (Fig 2.4 shows the REDM wire-frame, in red, overlaid on the site sketch). By recognising the value of the existing 3D wire-frame control, the sketch itself was uncontrolled and worked up entirely to fit the REDM guide lines in CAD.

Fig 2.5 CONTROL OF GEOMETRY BY TRIANGULATION (top left) in this example the plan is controlled by the use of triangulation. This is an effective method for using distance only measurement for 2D plots. The intersections are plotted to scale and the geometry mapped accordingly.

### CONTROL OF GEOMETRY BY DATUM LINE

(Top right) In this example the elevation is controlled by the use of AN IMPOSED HORIZONTAL LINE. This is an effective method for keeping control of horizontal elements in the elevation. (Example taken from Measured Drawing for Architects: Robert Chitham, Architectural Press 1980 ISBN 0 851 39 392)

### CONTROL OF GEOMETRY BY PLUMB LINE

(Bottom) In this example the profile of an elevation is controlled by the use of AN IMPOSED VERTICAL LINE (marked in blue). This is an effective method for maintaining control of vertical elements. The profile has been booked by tabulation.

Drawing is the most effective way of filling the detail gaps common in metric data sets: it is an effective verification tool. Guide and centre lines help the sketch; ruled lines are used when appropriate: the aim is to show the object clearly on the page. Heavier lines are used to clarify the edge lines that will be transposed into CAD. A REDM trace is a powerful tool for positioning drawings but complete reliance on traces for edge definition is best avoided, it is better to work with what is seen on site for large scale clarity. The proportions of the drawing need not be metrically precise but it is a key function of the drawing that the selection of edges be clear.

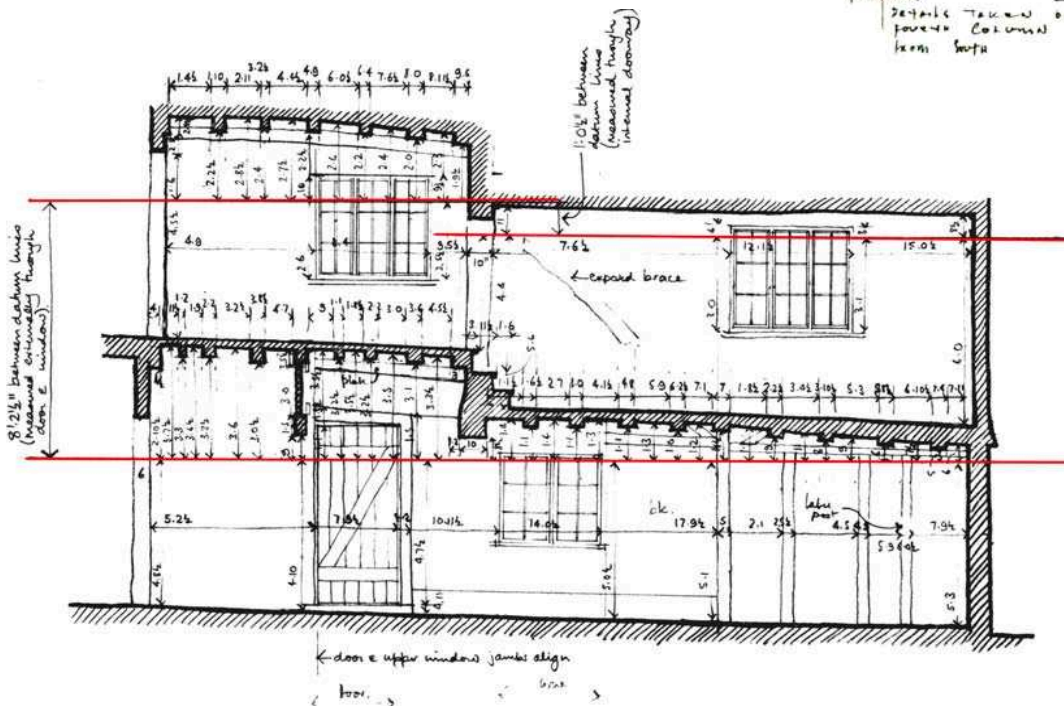
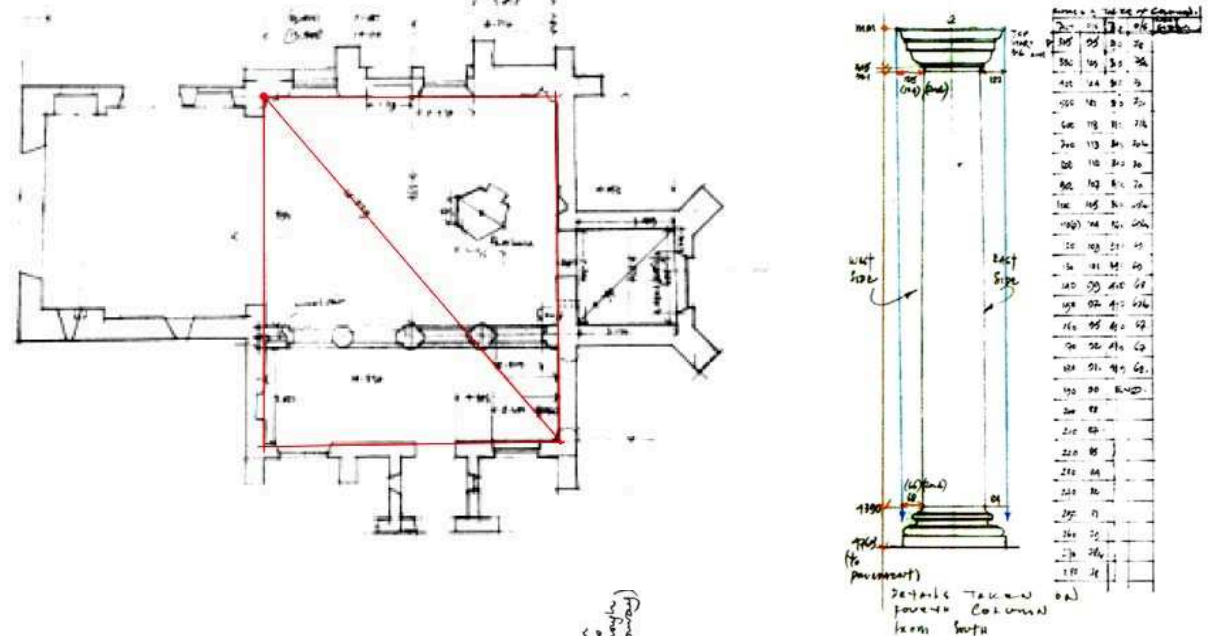

## CONTROL METHODS FOR DRAWINGS

Fixed reference (control) lines are a necessity in preparing drawings to be plotted at scale. Control lines should be used to achieve geometrically robust results. For elevations and sections the plumb and datum lines are reliable and can be achieved easily. Using braces to form triangles is effective control for room plans. As with all survey techniques, measuring needs to be systematic. Depending on the resources available, drawings can be controlled by:

- ♦ **Datum and plumb lines:** for elevations a reference line can be imposed on the wall with a levelled horizontal datum and vertical plumb, chalk line or pencil mark
- ♦ **Taped Triangulation:** usually used for plans. By measuring the diagonals of a room, its geometry is controlled while adding wall thickness gets the plan progressed from inside to out
- ♦ **EDM observations:** a rapid and precise method of establishing control points
- ♦ **Base line:** fixing the two endpoints of a base line can be done by taped triangulation or EDM. A base line is used as chain for *chain and offset* measurements.
- ♦ **wire-frame** from REDM and photogrammetric traces: for small areas control can be carried forward by overlap from existing survey

## DIMENSIONED SKETCHING

The drawing is prepared before measurement, enabling clarity of line and speed of recording. This is skilled work as it requires the accurate depiction and careful selection of relevant detail at the time of capture. The drawing first and measurement second approach is suited to maximising the surveyor's knowledge of the structure being recorded. Dimensions are added to the sketch in a number of ways. A vertical or horizontal datum for elevations or triangulation for plans achieves control. Control lines are shown on the drawing with a straight or tie line. Measurements to detail are taken at known points along the horizontal or vertical datum and recorded as dimensions on the sketch. It is common practice to plot measurement lines in red and datum or reference lines in blue to separate them from drawn lines. The same line weight emphasis as will appear in the finished plot is used to indicate edges and section lines. Missing measurements can compromise the integrity of the final drawing and are a drawback of this method, especially if the site can not be revisited. The use of photographs can help to overcome this problem.

**FINDING THE EDGES** In formal survey drawing if something is not defined by an edge it can't be drawn, so using sketched *guide lines* will help 'place the edges' and draw them in. Edges are not always clearly defined and some thought will be needed to decide where to place the line. For example a rounded column will have an

edge that is dependant entirely on the viewpoint of the observer: for survey drawing this will require the observer to record the line as it will appear on the plane of projection for the elevation.

## USING LINE WEIGHTS

The convention for line weight is simple: each successive edge is delineated with a thicker line, while the revealed details are shown using thinner lines. So the outline of a door opening is shown with a thicker line than the jamb mouldings around it. This is easy to express in the field drawing by using a heavier line on the sketch as appropriate: you can do this by using a softer pencil or drawing over the lines required a second time to get the emphasis.

## DIRECT PLOTTING

Measurements are recorded at scale on a drawing, which can be done by calliper and scale rule or by using a gridded plot medium such as graph paper. By placing a string grid on the wall or survey subject plane the surface is then plotted at scale onto a gridded drafting medium. A scale rule is useful to convert measurements and with practice many practitioners will end up producing the drawing to scale by eye. Alternatively, detail can be drawn at scale from calliper or taped measurements. If drawn at 1:1, fitted profiles taken from a profile gauge at full size can be used. Each

measurement and profile is added to the plot to build up a scale drawing of the subject. The view of the object selected must match the elevation view chosen for the section and any profiles must be taken accordingly. The fair copy is then traced or digitised directly from the field drawing. Direct plotting is widely used for large-scale work and is the standard method of archaeological excavation drawing. The advantage of direct plotting over dimensioned sketches is that it is possible to tell by looking at the drawing if all the measurements have been recorded. If a critical measurement is missing, the relevant bit of the drawing will be missing. The drawback is that more site time is required to produce a directly plotted drawing.

## 'PLANNING' IN EXCAVATION RECORDING

A planning frame is used to assist plotting the features revealed by excavation at scale. The drawings may form the record of the context as it is removed, so they need to be based on a reliable and systematic procedure as there will be no second chance to plot the information. Planning frames need to be level to the reference plane and linked to a common site coordinate system to enable the plots from each frame to fit together.

## DIRECT PLOTTING ON A VERTICAL PLANE

In the case of elevations the frame is flipped to record the vertical detail. The subject is controlled by the string grid on the planning frame and a fixed tape. The drawing is progressed by marking out the lines at scale referenced

to the grid on the plot.

Fig 2.6 DIMENSIONED SKETCH OF A PLAN, STEP BY STEP

- ◆ Use a drawing board, T-square, rolling ruler or graph paper to ensure that the lines in your drawing are squared up when needed.
- ◆ Size the sketch BEFORE YOU BEGIN so that you can fit the whole drawing on the paper and depict the smallest detail at a legible size.
- ◆ Draw a centre line and place guide lines to get the proportions right. Draw the principle lines with light lines.
- ◆ Mark off each of the length measurements - those that you took in the field - on a dimension line. Use a triangle to draw properly spaced, faint guidelines for the elements along the length of the item.
- ◆ Working anticlockwise around the plan, draw dimension lines alongside the elements as you measure. Mark off each of the measurements that you take. Use a triangle to draw faint guidelines for each of the measurements. Make sure measurements are controlled, either by triangulation (e.g. diagonals of rooms) or by reference to a datum or baseline.
- ◆ Draw the outline of the item itself using the guidelines that you've just set up. Use a harder lead or a different colour for measurements and a softer, darker lead to draw the item itself.
- ◆ Make space to write the dimensions on the drawing before actually writing them - they are the hardest parts of the drawing to fit in legibly and the most necessary to be read clearly at plot time.

## SKETCH DIAGRAMS

A sketch is any drawing prepared without measurement to help understand the object being measured. Sketches are useful when combined with measured data from

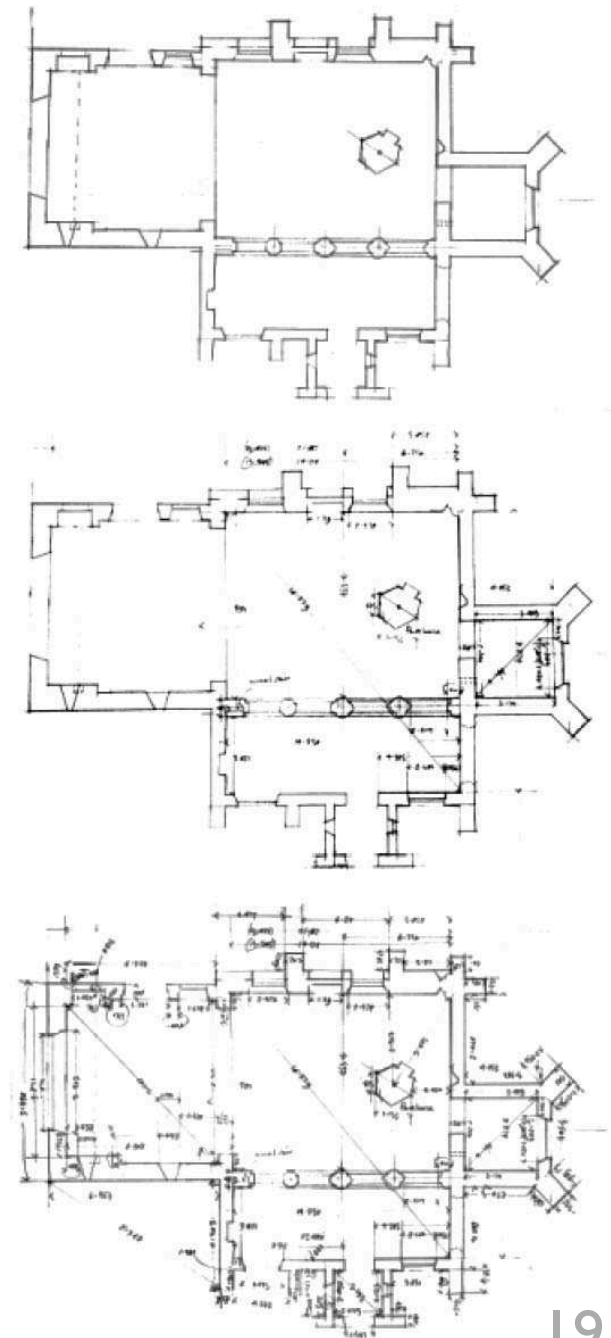

other sources. It should be remembered that like all survey techniques, sketching will benefit from a consistent and systematic approach.

**DIAGNOSTIC DETAILS** This term describes features that support a theory about how a structure or component fits in to our understanding of an historical sequence; once recognised, these key features need to be recorded to substantiate our findings. Site sketches are often an ideal way of doing this.

**CHOOSING LINES** If there is uncertainty over how a feature should be depicted then the process of identification, type history and form analysis should be used. If the right questions are asked of an object, the drawing will be effective:

- ◆ How do the lines bound this object?
- ◆ How is it developed from its design?
- ◆ What is the prototype it is derived from?
- ◆ What is the architectural form used?
- ◆ What are the functions of the component?
- ◆ Does the viewpoint affect delineation of edges?

Drawings must show a clear line selection, as the lines clarify the measurement and define the edges selected. Hence drawings are often needed where a photograph could not define the edges needed for a survey.

#### ANTICIPATE END USE

Because drawing is so dependent on clarity of selection it is vital for the draughtsperson to know what the requirements of the survey are:

- ◆ Will the drawing clarify the detail to help build a 3D model?
- ◆ Will it enable a wire-frame to be edited into a CAD drawing or will it simply help define edges where they are indistinct?

**ANNOTATION** Descriptive text on the drawing should be limited to that which is not revealed by the drawing or associated photography. Notes on material, colour and context should be placed well clear of the drawn lines and limited to the requirements of the brief: if the brief calls for a written description you should not be drawing. All drawings, be they measured drawings or sketches, should be clearly and concisely labelled, with the drawing layout including:

- ◆ The site name and location
- ◆ Date of drawing
- ◆ Direction of view
- ◆ Draughtsperson's name
- ◆ A location diagram

*Fig 2.7 Sketch and CAD model of the crown joint of the Ironbridge at Coalbrookdale made as a record of an inspection made by probe and hand mirror.. The clear indication of the casting shapes is more important than the accurate depiction of proportions, as these were obtained by REDM and Photogrammetry.*

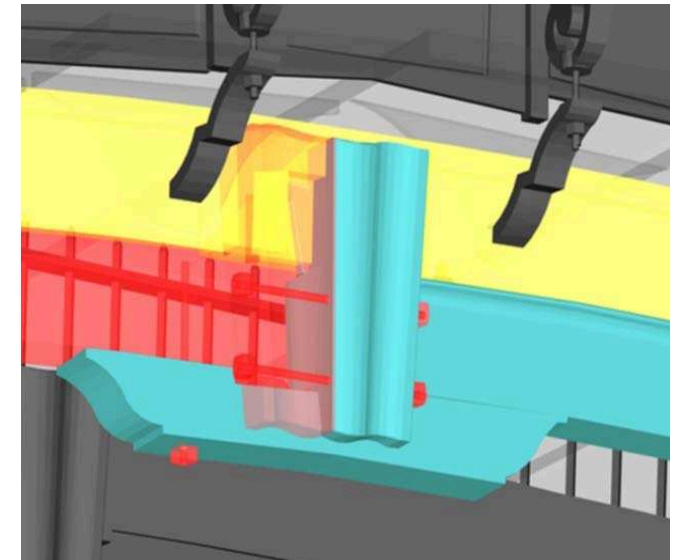
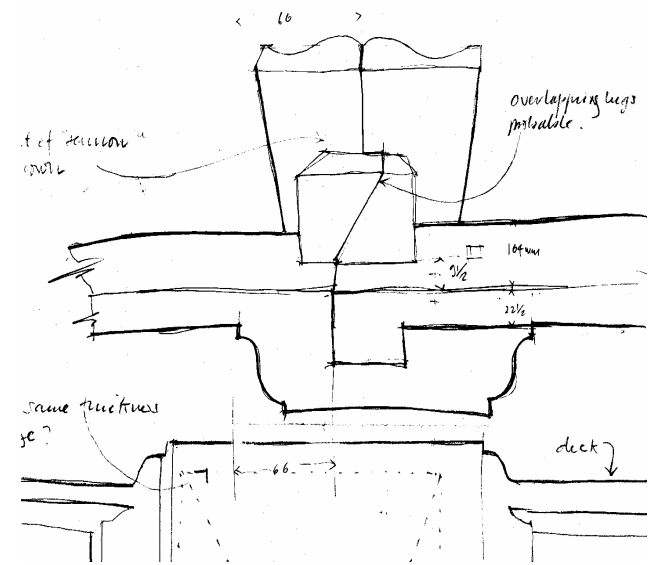



**META DATA PREVENTS DRAWING MISUSE!**

Metadata is crucial to the utility of the information we record by systematically including the details of who made the drawing, why it was done; the expectations of those using it can be based on fact rather than supposition. The title box contains all the information needed to identify the origin of the drawing and its purpose. It is the declaration of the provenance of the work. Annotations should be used to link ideas to the drawing: a sketch plan can be used as an index to explanatory notes. A common form of CAD drawing is the wire-frame where edges are shown as lines in 3D. These drawings only work when viewed from the plane of record but contain 3D geometry. Wire-frames can be captured by photogrammetry, REDM or by plotting x, y and z co-ordinates and are often used as an armature to develop detail from drawings or photographs. They are also a good basis for model building in CAD.

Fig 2.8 William Thornhill's sketch of the plan of Landguard Fort in 1711 records the trace of Darrel's fort in a few lines selected to show earthworks, gun emplacements and buildings. This fort was obliterated in the 20 years between Thornhill's visit and the construction of a new defence of the Landguard Point; his sketch is a rare record of the layout of the first fort. He uses key letters to identify points of interest and link them to his notes. The drawing is valid today because he adds a description of what it is: "...to Landguard Castle whiche makes a good Fortification..." the meta data of the record makes it useful.

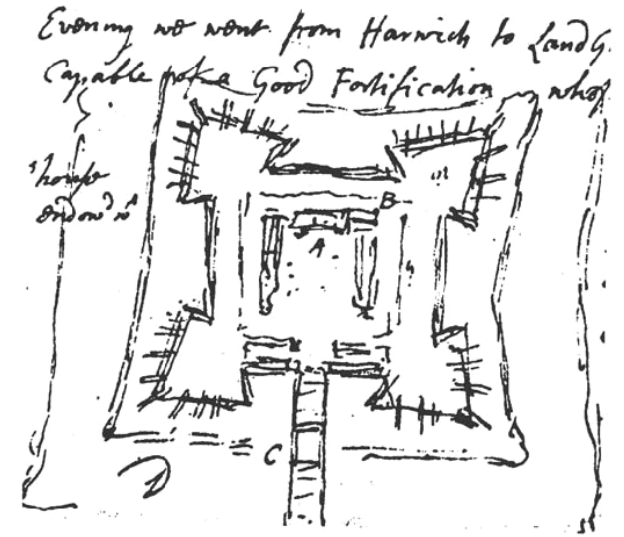
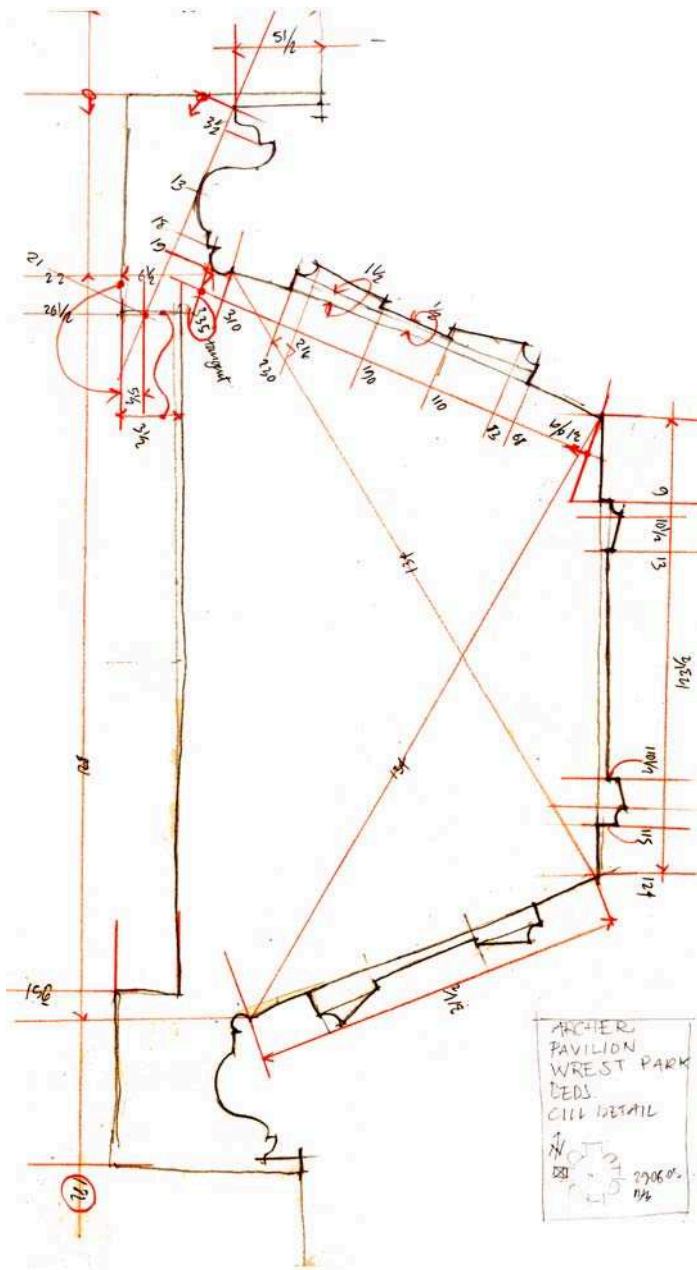

Fig 2.10 (Overpage Right) Drawing on site concentrates attention on selection and lets our observation work in a structured way. Taking the time to think through line selection and identifying key detail and geometry is important to getting the best achievable quality into survey work. Approaching the drawing carefully is always better than 'drawing on the run'. A good field drawing takes time and composure, organising the sketch means careful observation and selection of line: a drawing should be prepared when its necessity is clear. If the information can be captured with a photograph the investment in time required for drawing should be placed where it is most useful: cill, stair and door lining details are typical of subjects that need dimensioned sketches to be resolved.



### USING SITE DRAWING TO ACQUIRE KEY 3D DRAWING DETAILS

The site drawing should be prepared in conjunction with the wire-frame if possible, as this is the best way to be aware of the missing faces in the wire-frame. If it is not possible to prepare the drawing on site at the time of capture (i.e. if the wire-frame has been prepared by photogrammetry) careful inspection of the wire-frame should be made and a site visit planned to infill the key details by measured drawing.

### FITTING HAND MEASURED DATA TO WIRE-FRAME

The model geometry can be developed from the wire in 3D by judicious use of UCS fitted to the wire and offset by the recorded measurement. For 2D work there are two routes depending on the type of drawing used. For measured drawing the measurements are plotted directly into CAD as local polar positions or Cartesian values. Plotting from drawn notes can be achieved by using offset circle, arc and line for translating measurements. Direct plots can be digitised by tracing on a digitising tablet or from a scan of the drawing scaled to the wire-frame (heads-up digitising)

Fig 2.9 The dimensioned sketch needs to be clear, organised and use a robust measurement technique: if it cannot be reconstructed at scale the effort is wasted. Note the title box: this is the drawing metadata. Defining a drawings provenance is one way of protecting drawings from misuse by including in the title box the site name, component, location, scale, date, reason for survey and the draughtsperson's identity.

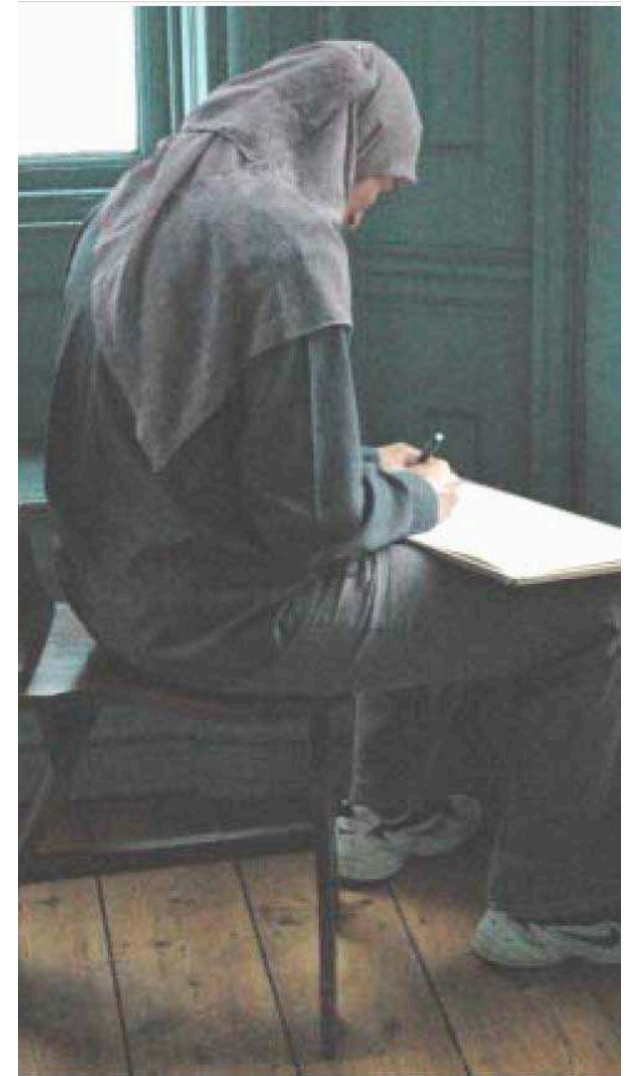

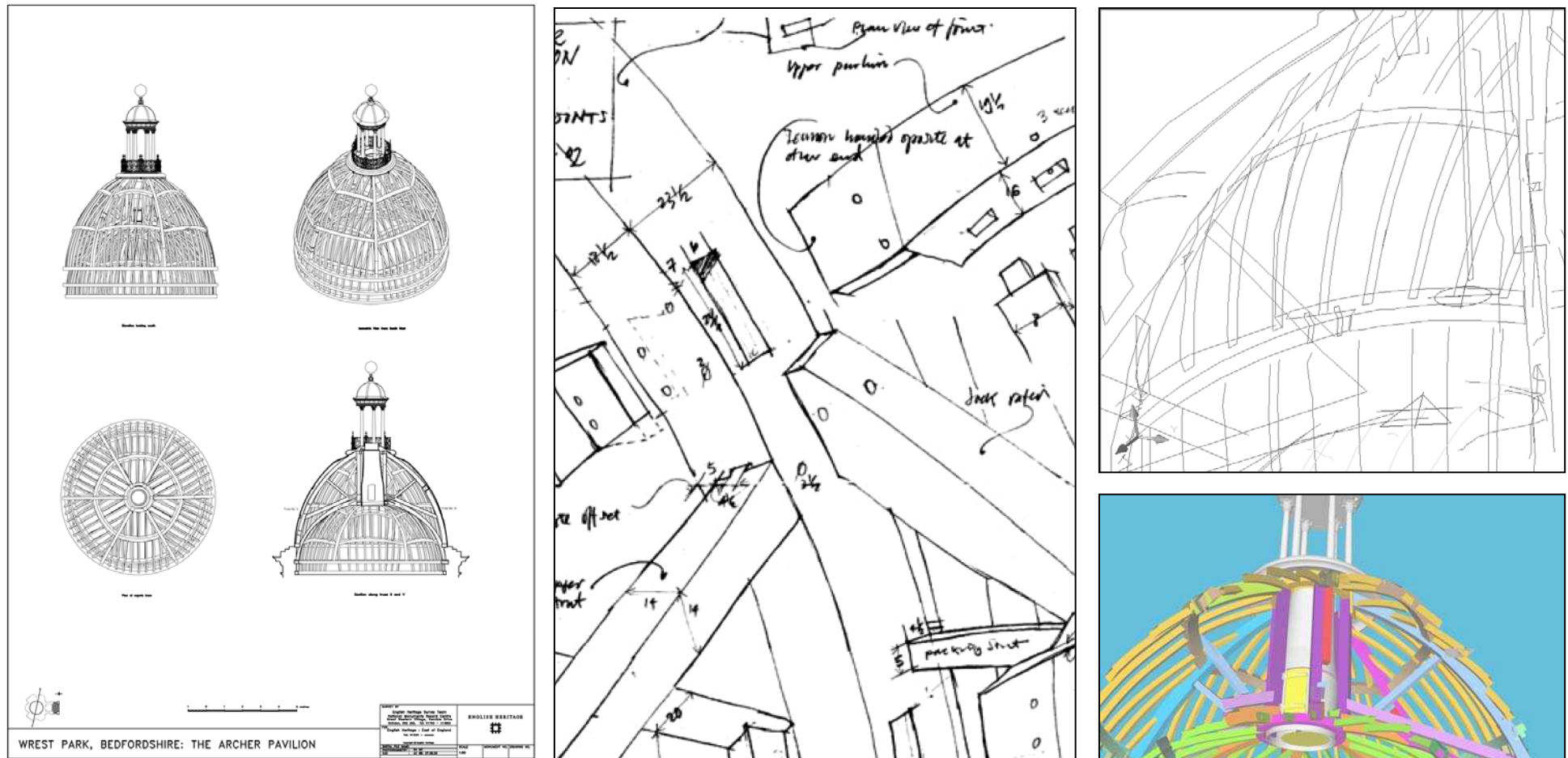

Fig 2.11: DRAWING SKETCH, WIRE FRAME & MODEL

The sheet layout (above) must meet a minimum polite layout: a section should be shown in relation to its plan and laid out in correspondence to the view shown. Architectural convention determines the line weights and the relationship between the plan and the sections as indicated in the key plan. The metric wire-frame (top right, this example is from REDM) is used to position the detail from the annotated sketch (above). The result is that the wire-frame can be developed into a model (bottom right) and, in this case, drawings extracted from the model using 'solid profiling' to project the edges to the plane of view (left) as 2D data in the presented CAD plot.



# PRESENTING THE DRAWING

## BUILDING CAD MODELS

The wire-frame allows the positioning of prototype profiles which can be extruded to form the solid geometry bounded by the lines. The wire-frame will need supplementary information from site notes to complete the profiles needed. For 3D work we need measurement of all 6 faces of a cube rather than the 3 or so available from any one viewpoint!

## DIGITISING DRAWINGS: MATCHING THE POINT DENSITY TO THE REQUIRED OUTPUT SCALE

When tracing into CAD it is important to anticipate the output scale of the tracing: the CAD view is often misleading when compared to an A1 draughting sheet: a common mistake is to pick fewer points than the scale requires resulting in 'spiky' lines at plot scale.

## DERIVING LINE DRAWINGS FROM THE MODEL

It is possible to derive line drawings from models provided the model is of a parity sufficient to meet the scale requirements of the line drawing. This is an important consideration as the effort required to model at an adequate parity may outweigh the advantage of preparing the model! If the subject is reasonably uniform and component-oriented a model will be useful. If the project demands depiction of a wide variety of unique forms a model will be a time consuming distraction from the needs of the project and should be avoided! In Fig 2.16 the model was an effective route to handling the radial geometry of the subject. A drawing set of plan, sections, elevations and isometric views was generated.

## COMMUNICATION OF THE MEASURED WORK

Plotting the measured drawing is the final step in sharing the information gathered by drawing: it is at this point in the process that the standards and conventions required must be applied. Standards will describe the correct line weights to use, the required layer structure (for CAD), the correct use of symbols and the correct sheet layout and rubric. Some standards also prescribe the media to be used and the deposit and accession procedure



Fig 2.12 Sectional elevations laid out on a sheet with correct rubric: showing key plan, north point, authorship scale etc.

required. A list of current standards is included at the end of this section.

**THE FAIR COPY** Formal presentation will require a sheet border, title, location plan and scale bar. The extent of the subject, the text styles and sizes should be in agreement with the specification. For large projects or wide area programmes it is advantageous to plot drawings in CAD for digital transmission. Measured drawings are plotted at scale on an archive medium in anticipation of the drawing forming a record with a long life. The information on the drawing should be formally organised with the correct convention for line weights, section lines, location diagram etc. Depending on the project requirement the drawing sheet(s) will contain the drawing elements *plan, section and elevation*.

**THE ARCHIVE AND CAD** When preparing plots in CAD it should be borne in mind the difference between the CAD view and the plot can lead to a false sense of quality. The plotted result should match the drawing requirement: it is wise to test line weights, line type and line style at the plot size before committing a CAD drawing to archive. As the digital drawing has an uncertain future it is wise to deposit hard copy plotted on archival media together with the CAD drawing issue.

## STANDARDS AND CONVENTIONS FOR HERITAGE DOCUMENTATION DRAWINGS

HABS/HAER states: *Documentation shall adequately explicate and illustrate what is significant or valuable about the historic building, site, structure or object being documented.* For successful documentation an appropriate standard of presentation must be adhered to. The detailed application of standards by convention begins with the minimum requirement to present the metric information clearly and extends to include stylistic and thematic elements as required by the nature of the subject and the purpose of the record. Different specialist disciplines have different conventions:

For Building Archaeology: EH 2006 *Understanding Historic Buildings: A guide to good recording practice*, Swindon: English Heritage

Metric survey for conservation: EH 2000 *Metric Survey Specification for English Heritage*, Swindon: English Heritage

For Industrial Archaeology:  
*Library of Congress HABS/HAER: Secretary of the Interior's Standards and Guidelines* [http://www.cr.nps.gov/local-law/arch\\_stnds\\_6.htm](http://www.cr.nps.gov/local-law/arch_stnds_6.htm)

For archaeological landscape survey: RCHME 1999 *Recording Archaeological Field Monuments: A Descriptive Specification*, London: RCHME

Metadata standards: The Dublin Core metadata element set is a standard for cross-domain information resource description. <http://dublincore.org/documents/dcmi-terms>

The ICOMOS 'Sofia Principles' Detailed description of the actions required for heritage documentation under the Venice Charter Article 16 requirements.  
[http://www.international.icomos.org/charters/recording\\_e.htm](http://www.international.icomos.org/charters/recording_e.htm)

# DRAWING TERMS & TECHNIQUES

braced diagonals	Triangulation method used to control the geometry of a plan. A rectangle can be skewed, by measuring its diagonals AND its sides the angles will be reproduced when the arcs cast by the lengths intersect
cad	CAD (Computer Aided Design/Draughting) is a digital 3D environment used to prepare metric drawings. It allows metric information to be assembled in a scale free geometric space that replicates the 3D volume of the world we perceive. This advantage is balanced by the need for all objects to be bounded by clearly defined edges as either vertices or surfaces. CAD will not readily handle diffuse unbounded data such as point-clouds and is driven by the drawing production needs of design and construction: in heritage documentation it is used to map existing objects and transmit drawings to those engaged in conservation. There are two routes to transferring drawings into CAD: plotting the measured geometry or tracing either with a digitising tablet or 'heads up' from a scanned copy of the drawing.
chain & offset	Taking measurements along a line (the chain line) and taking short measurements from it at right angles. Chain and offset is a method of mapping detail on small surveys where the chain lines are fixed by triangulation. The results are usually tabulated (in a chain book) or annotated to a field sketch.
control	Frame work of measurements of a higher order of precision than that used for mapping detail. Control in survey is the primary geometric framework from which local measurement is derived. It can be a simple base line between 2 points of known position or a reference line established with a plumb line or spirit-level. For precise work, control is established using EDM or rigorous taped triangulation.
cut line	The line that is depicted 'as cut' for a plan or section. Usually shown with a heavy line weight. This architectural convention traditionally puts the height of the cut line for plans at between hip and shoulder height to show the openings etc.
datum line	Level line used to transfer heights.
digitising	Transferring into a digital format, usually by tracing over drawn lines or photographs to get details into a CAD drawing. There are 2 methods, 'heads up' on the CAD graphics area or by use of a tablet.
dimension line	A line used to record a measurement
EDM/REDM	Electromagnetic Distance Measurement; when combined with a theodolite known as TST (Total Station Theodolite). Some units are equipped to measure without a prism known as Reflectorless EDM: REDM. Methods of use vary and can be either post-process or real-time with the measurements recorded in CAD. Used for control measurements and producing wire frames.
guide lines	A line drawn to indicate the approximate extent of an object, sometimes called a ghost line. Guidelines typically pick out the centreline and principal proportions of the subject.

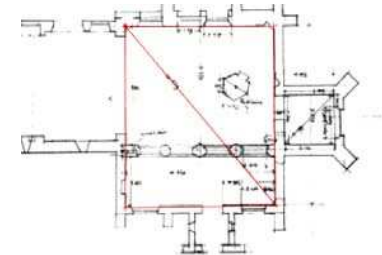

*Braced diagonal used to fix room geometry.*



*Surveyors rod (folding rule) being used as a chain line with offsets to moulding detail being taken by tape.*

*EDM is a common term used to describe a 'total station' or combined electronic theodolite and distance meter... Tachometer is another common term for devices that measure distances.*

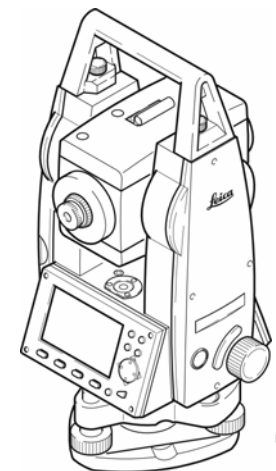

laser scan	Method of mass 3d point capture using an automated laser. Produces point-clouds.
line weight	The thickness of a line relative to other lines
metric	Data which Includes measurement as a primary property.
Permatrace	Proprietary name: K& E drafting material (no longer manufactured).Dimensionally stable draughting material, known as draughting film.
perspective sketch	A 3D transcription of a detail with a view point and suggestion of distance to aid the sense of proportion.
planning frame	A rigid frame, often 1mx1m or 2mx1m used to set a grid of string lines at, for example, 20cm intervals, against the subject to be drawn. Planning frames are typically used to generate 1:20 plots on draughting film that are then traced into CAD or inked up as fair copy of excavation records.
plumb	Vertical line. A suspended plumb bob describes a vertical line in space.
point cloud	A mass of undifferentiated points in 3D space: a typical laser scan product.
polyline	In CAD a continuous line. a polyline can be smoothed or used to bound an object.
profile gauge	Tool for taking a copy of a profile. <i>A profile gauge is one method for getting moulding profiles</i>
ruled up drawing	Also know as 'as designed' drawing, drawings prepared on the basis that a building is recorded using its formal architectural components
shading /hatching	Methods of indicating 3D in a drawing, not usually used for metric records but vital to the record drawing of small-finds for publication.
UCS	CAD constraint for both view and 3D development. User Co-ordinate System in AutoCAD®. (known as ACS Ancillary Co-ordinate system in Microstation®).
Wire-frame	3D 'edge only' mapping of the subject. Wire frames can be used as drawings or as the armature for modelling. Wire-frames rarely perform well as 3D models without development of surface or solid geometry.



*Planning frame placed over an excavation for direct plotting drawing at scale. The 5cm squares can be matched to the grid squares on the drawing medium*

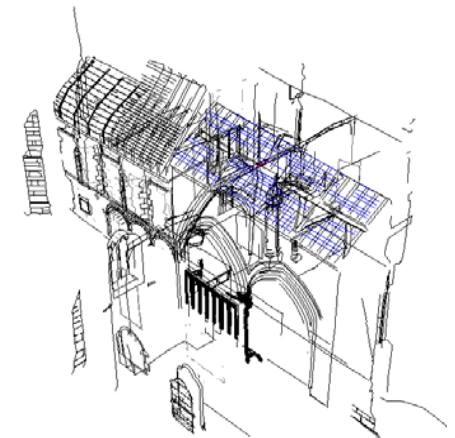

*3D Wire- frame used to prepare a sectional elevation*

## TOOLS FOR MEASUREMENT



**3m steel tape** Deals with the short distances the Disto® doesn't! A tape marked in cm units rather than dual inch/cm will avoid confusion.



**Folding rod or builders rule** Useful in measuring at arms length, for example overhead beams



**Disto® - a hand held EDM** Measuring longer lines, up to 30m. Late models have a useful min/max distance function for measuring diagonals and a Bluetooth link enabling it to draw in CAD using TheoLt.



**Callipers** For diameter and thickness measurements

## TOOLS FOR SETTING OUT



**Spirit level** Transferring a local datum and checking verticals. Choose a level with horizontal and vertical bubbles.



**Plumb bob and line** For vertical datums, trickier to use than the spirit level but more reliable. Very useful for transferring control up flights of stairs etc.



**Water level** Transfer of datum from one place to another, particularly on sections to ensure floor and ceiling heights are correctly related. Also used for placing levelled targets on a wall for photography.



**Chalk line** A chalk line is a quick way of setting out a straight line to measure and draw from. Measurement by chain and offset often needs an arbitrary straight line; the chalk line is ideal. For long lines you may need 2 people.

## DRAWING INSTRUMENTS



**Clutch pencil** On cartridge paper an HB lead will do for most work. If you are using drafting film 2H to 8H are needed.



**Compasses** Compasses can be used to plot arcs for intersection measurements as well as to draw arcs and circles. For site work use a pair that fit your pencil!



Use the set-square, T square and compasses to guide the drawn lines. Use compasses for arcs, to set centres and to gauge the proportions of the drawing.



**Eraser** Keep rubbers clean and keep your drawing clean! Clean up the drawing as you go: erase guide lines Pencil rubber where they are not needed to avoid confusion with detail lines.



Use the set-square, T square and drawing board together. A3 is a good size. Board clips, used with care, are the best way to hold the paper on the board.



**Scale Rule** Essential for direct plotting and checking scale drawings.

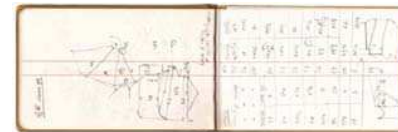

**Chain book** The chain book has its own discipline: tabulated measurement. Where repeated measurements need to be noted the chain book is the best place to do this.



**A good camera and tripod.**

The better the photographs the more useful they are! Using a medium-high resolution camera will improve and the quality of images and thus the quality of information recovered from them.

FURTHER READING:

Burns, J A (ed) 2004 *Recording Historic Structures*, New York: John Wiley & Sons Inc ISBN 0-471-27380-5

Chitham, R 1980 *Measured Drawing for Architects*, London: Architectural Press ISBN 085139 32 6

Evans, G W 2005 *Photography for surveyors*, Elsevier Science and Technology ISBN 0-7282-0477-0

Forsyth, M (ed) 2007 *Structures and construction in Historic Building Conservation* Blackwell Publishing ISBN 9781405111713

Hill, M 1999 *A guide to drawn information*, RIBA Publications ISBN 1-85946-051-8

ICOMOS 1990 *Guide to Recording Historic Buildings*, London: Butterworth ISBN 0 7506 1210 X

Lunnon, S (ed) 2003. *Measured & Drawn: Techniques and Practice for the Metric Survey of Historic Buildings*, Swindon: English Heritage ISBN 1 873592 72 8

Reekie, F and McArthy, T (ed) 2002 *Reekie's Architectural Drawing*, Oxford: Butterworth-Heinemann ISBN 0 340 573 24 4

Styles, K and Bichard, A 2004 *Working Drawings Handbook*, 4th ed. Architectural Press ISBN 0-7506-6372-3

Schuller, M 2002 *Building Archaeology*, München: ICOMOS (Monuments and Sites: VII) ISBN: 3-87490-677

Werferlin, Ullrich; Heine, Katja ; Wuilf Ulrike: (eds) 2001

Von Handaufmass bis high tech, Aufnahmeverfahren in der historischen bauforschung

Phillip von Zabern Mainz ISBN 3-8053-2818-4

# Documentation for conservation

## A Manual for Teaching Metric Survey Skills

# 3

E D M

PART 3

TECHNIQUE SUMMARY:

T  
E  
C  
H  
N  
I  
Q  
U  
E

- Surveying With E D M
  - The elements of EDM Measurement
  - Data logging
  - Working with real-time CAD
  - Control by EDM
  - EDM traversing
- Direct measurement, selective

OBJECT SIZE 10m<sup>3</sup> to 0.5km<sup>3</sup>

PRECISION +/- 2-3mm at 100m range  
HARDWARE Total station theodolite, tribrachs, tripods, targets & prisms

SOFTWARE Co-ordinate computation  
Traverse/network  
Coding translation  
Terrain modelling  
CAD

SKILLS REQUIRED	APPLICATION
Field skills: observation, selection.	Recording selected 3D points
Correct point density and interpretative selection, understanding of interpolation	
Instrument handling: Centering, levelling, measurement procedure	Traversing to provide precise control data for maps and plans
	Digital Terrain Models (DTM)
	Wire-frame model armatures
Systematic observation and error trapping, anticipation of results	
Understanding of scale and appropriate point selection in anticipation of end use	Topographic surveys of small sites
	Plans & sections of buildings, simple elevations. Complex when used with photography for details
	Control points for rectified photography
Understand calibration regime	
Equipment environment ,transport ,care and maintenance awareness	
IT literate	
Survey skills required	
CAD literate, 3D aware	
Vectorisation, layering and line weights/scale	



Astronomers in the 17th century understood that a beam of light could be used to measure the distance from one point to another, but it was the rapid development of electronics during and after World War II that made the practical implementation of this idea possible. The Geodimeter, the first EDM using visible light, was produced by Eric Bergstrand in Sweden in 1953, followed by the Tellurometer (which used microwave radiation), first produced in South Africa in 1954. Infrared EDMs became fairly widely available in the late 1960s, and it is this technology which is in common use today. EDMs are considerably more expensive than the tools employed for more traditional measurement techniques, but also offer considerably more precision and flexibility, and they have displaced traditional distance measuring tools for many survey tasks.

#### CO-ORDINATE SYSTEMS - THE COMMON POSITIONAL DESCRIPTOR

Metric survey is the process of positioning objects by measurement. Position can be expressed in 2 ways on a map; as a Cartesian co-ordinate or as a polar vector. A vector uses direction and distance whereas co-ordinates describe points using relative position along 3 axes (x, y, z) by distance. Co-ordinate systems can be local, national or global and use *Easting Northing* and *Height* to determine the axes. Vectors are common to local and navigation systems where handling angular data is important. Co-ordinate systems are the standard positioning descriptor in survey, mapping and CAD.

#### TECHNICAL OVERVIEW

This section aims to provide a rough guide to the workings of EDM, to give enough information to enable an understanding of the basic principles, and how they can affect choices made when considering working with such an instrument.

#### DISTANCE MEASUREMENT

Most EDM instruments use a near visible light source to measure distances due to relatively low cost and power requirements. The instrument emits an electromagnetic beam in the form of a modulated sine wave. This signal is reflected at the target (e.g. a retro-reflective prism), returned to the instrument and distance is calculated by measuring the number of whole wavelengths and the phase shift between the outgoing and return signals. An EDM measures distances only. When it is combined with an electronic theodolite, the combination functions as a Total Station (TST). As such, it measures horizontal and vertical angles as well as distances, giving precise measurements (e.g. +/-2mm at 2ppm at 1.8km; 1ppm = 1mm in 1km). Maximum range is usually about 2km, but this range can be extended by using special prism arrays.

Rapid and precise measurement using infrared EDM gives a reliable framework for survey work of all kinds but especially in close range work (0.25 to 100m). Precision is dependent on the density of recorded points and the method used. The use of EDM is becoming more widespread and its application to close range detail work is now possible with reliable reflectorless EDM (REDM) and real-time links to CAD from software like TheoLt. The guidance on technique offered here should be used in conjunction with the recommendations of the manufacturer and suppliers of the hardware and software involved.

Fig 3.1

#### TYPICAL E D M

This example is a device with reflectorless capacity up to an 80m range. An EDM is costly and fragile: it must be handled with care!



# THE ELEMENTS OF EDM MEASUREMENT

## ANGULAR MEASUREMENT

A total station combines an EDM with electronic horizontal and vertical circles. With this device, as with a theodolite and tape, one may determine angles and distances from the instrument to the points to be surveyed. Using trigonometry, the angles and distances may be employed to calculate the Cartesian coordinate positions (x, y, and z or easting, northing, and height)

of points of detail in relation to the instrument. The same method can also be used to determine the position and orientation of the instrument by observation to two or more points of known position. A total station uses a telescope with cross-hairs for sighting a target; the telescope is attached to a 'graduated' horizontal circle for measuring the angle of rotation and a vertical circle to measure the angle of inclination of the

telescope. After rotating the telescope to aim at a target, one may read the angle of rotation and the angle of inclination, usually from a digital readout on the instrument. The electronic theodolite is both more accurate and less prone to user errors such as misreading the Vernier scale or mis-recording on a traditional theodolite. Most modern instruments measure to between 0.5 and 7 seconds of arc, depending largely on price. The slope distance, inclination and horizontal angle to the prism are the products of the measurement process, and simple trigonometric calculations permit the transformation of this data into horizontal distance, bearing and vertical height difference.

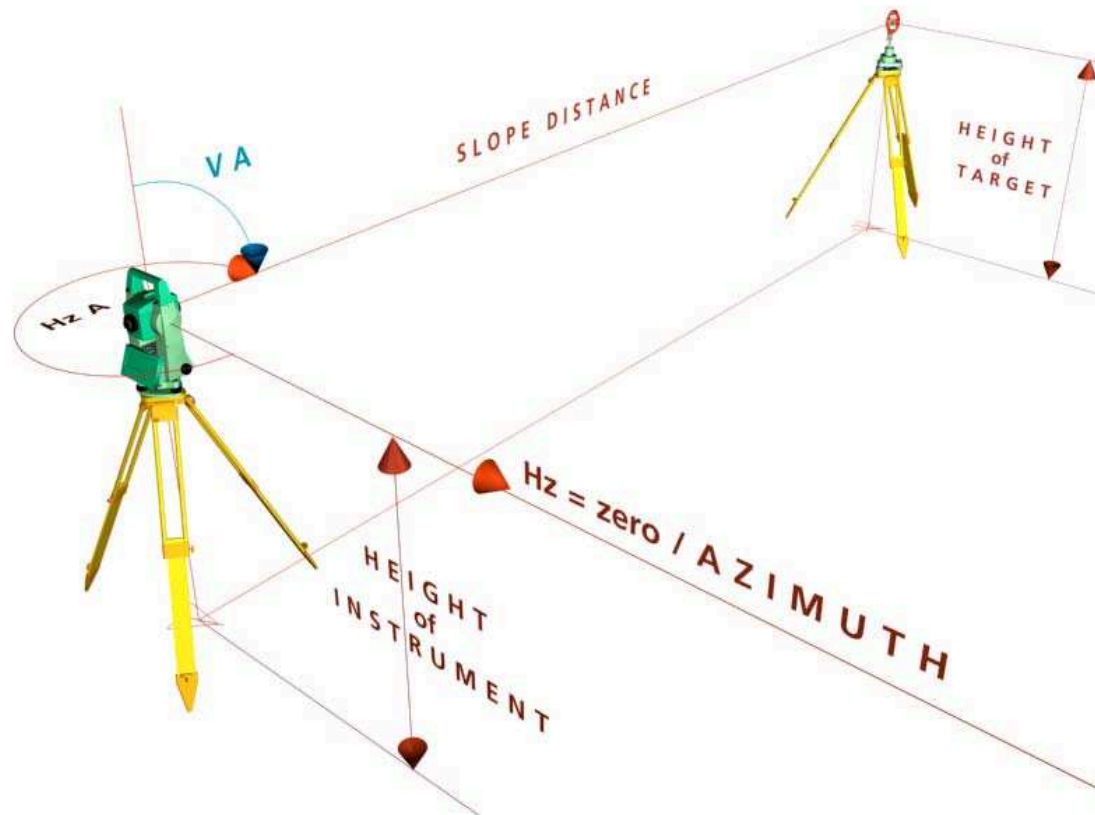

Fig 3.2 EDM distance measurement instruments are combined with angular measurement to record the relative direction in the horizontal and vertical planes. The height of the instrument above the station point and the height of the reflector above the target point must be recorded for true heights to be measured. The axes of measurement of both the instrument and target must be truly vertical and truly horizontal to avoid error.

## DISTANCE MEASUREMENT BY E D M

EDM works by bouncing an infrared beam off a target and recording the properties of the returned signal to calculate the distance. The results are dependent on the quality of the target and, to a lesser extent, atmospheric conditions.

The instrument measures 2 angles and a distance to record the position of a target. The heights of the target and the instrument need to be known to relate them to points on the ground. The distance recorded is the hypotenuse of the right angled triangle formed by the target, instrument and the vertical angle. Angular measurements are made with reference to the horizontal plane for verticals and an arbitrary zero for horizontal angles (HZ=0).

## SOURCES OF ERROR

There are three principle kinds of error when using an EDM: random errors, systematic errors and gross errors. Random errors cannot be avoided but their presence must be detected by anticipation of a given result. Systematic errors can usually

be ameliorated by good procedure. Gross errors are usually the result of a major omission in observation procedure, for instance failing to record the correct height of target when measuring points with a detail pole is a typical gross error. The commonest systematic errors are described as nearly all of these can be compensated for by use of the correct application of procedure or by correct use of the instrument itself.

### ADDITIVE ERRORS

The distance measured by the EDM may require adjustment due to the instrument measurement position not being centred relative to the instrument (i.e. not vertically centred over the point being measured from) and/or by the zero axis of the prism not being vertically aligned over the centre of the tribrach (commonly referred to as the prism constant). These are commonly combined to form the additive error. The former value is constant for any given instrument, and usually compensated for by the instrument automatically. It is often the latter that can cause some problems, as it is variable from prism type to prism type (typical values are 0, -17.5mm, -34mm) and not therefore compensated for automatically by the instrument. If switching between two prisms with different constants, you must remember to change the prism type used on the instrument before taking a shot, or the results will be in error. Similarly, you must remember to switch from prism (IR) to reflectorless mode (RL) before measurement commences if using REDM.

### SCALAR ERRORS

Scalar errors can have a number of causes, but are usually caused by variations in atmospheric temperature and pressure, which cause changes in the velocity of the transmitted beam, and therefore change in the wavelength. The 'thinner' the atmosphere, the longer the wavelength of the beam. These errors are expressed in parts per million (ppm) and can be

compensated for when using the EDM (usually by inputting the revised data in the appropriate section of the on-board software) if the temperature and atmospheric pressure are measured. As an example, a 1 degree change in dry bulb temperature is roughly equivalent to a scalar error of about 1ppm, or 1mm per km.. Where a site covers a large area or is to be recorded as part of a wider area, project co-ordinate values need to respect the projection used to map the wider area. Local and National grids use a projection to transfer the curvature of the earth and the effects of variation in height to a plane. A scale factor is used to correct for the projection used: this can be applied at the point of capture or as a post process adjustment. It is important to ensure that if a scale factor is to be applied all members of the recording team are aware so that the mismatch between adjusted and unadjusted work can be anticipated. Control points derived from GPS survey should be supplied with a statement of the projection used and a local scale factor.

EDM survey is rapid and precise but requires the surveyor to select the data to be recorded in the field: it is not a mass data capture method like photogrammetry or laser scanning. Single face observations are made from fixed points or stations. Depending on the size and complexity of the job further stations may be set out as required or a traverse used to link sets of polar (or radial) observations together.

Operators of EDM instruments should be familiar with common survey practice so that they can set up over a point and understand:

- the expected performance of angular and distance measurement
- the importance of level and plumb axes for measurement calibration and verification of instrument error
- the correct sequence of measurement to ensure appropriate precision for both control and detail work
- the appropriate point density for the desired drawing quality at a given scale

Fig 3.3  
 THE AXES OF MEASUREMENT OF AN EDM INSTRUMENT  
 Standing Axis = SA                      Horizontal Circle = HK  
 Tilting/trunnion Axis = KA              Vertical Angle = V  
 Vertical Circle = VK                      Line of Sight = ZA  
 Horizontal Angle = HZ              Zero Horizontal Angle = HZ0

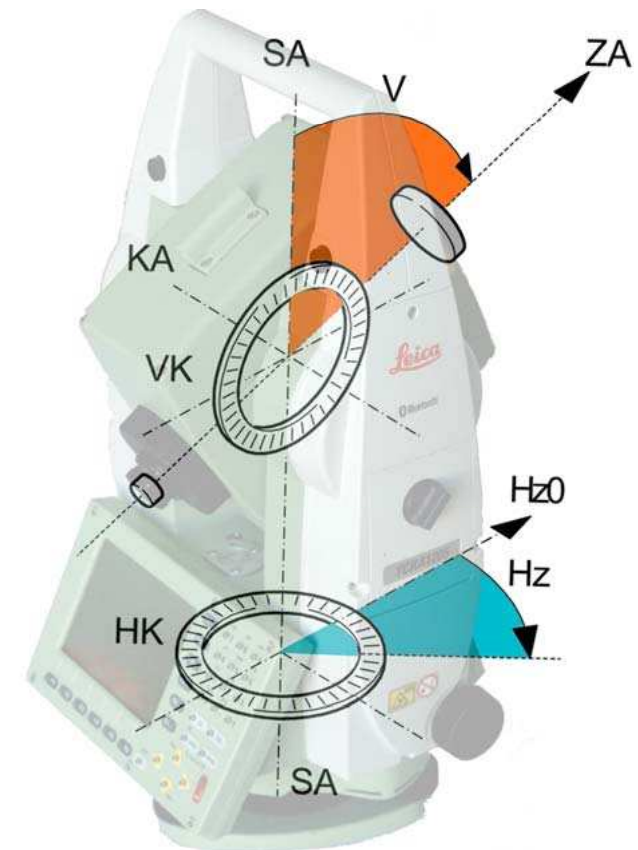

Because EDM data is digital it is easily used in a CAD environment and can be employed to:

- Build up CAD drawings directly on site
- Construct wire-frame to control hand survey work
- Control the rectification and digitising of drawings and photographs
- Infill and supplement 3D photogrammetric, laser scan or GGPS data

EDM units are available with combined EDM and REDM functions; this is very useful for building recording work. Instruments that use a visible laser as a pointer for reflectorless



Fig 3.4 PRISM MOUNTED ON A TRIBRACH

For precise work fixed points need to be set out carefully: using a matched set of prisms and tribrachs are essential for reliable work, if targets are improvised precision will be compromised!

measurement speed up pointing and can help to increase the density of recorded points. REDM uses the same principle as reflector based methods but will operate over a useful range of 5 to 200 metres without a prism.

This has two principal benefits:

- Speed of targeting
- Access to remote targets.

REDM can be operated as a one-person system given the redundancy of placing a prism reflector at the target. In practise two people are often required, both because subjects usually require a mix of targeting methods to provide complete coverage and for Health and Safety reasons.

## REDM PRECISION

Data captured using an REDM needs careful monitoring so that spurious points can be removed. Three variables that can affect the precision of the reflectorless measurement, and can be responsible for spurious points are:

- *Range:* the return signal is diminished and the contact area of the measuring beam is increased with long range observations.
- *Obliqueness:* the ambiguity over the targeted point increases with the obliqueness of the observation and distances will be corrupted.
- *Reflectance:* the reflective quality and surface texture of the target will effect the ability to measure distances.

Target and station positions are determined by these variables: stations will need to be close to the subject, and targeting to edges with an oblique aspect to the instrument should be avoided.

## OBTAINING GOOD REDM DATA SETS

Four simple steps will help to get the best from reflectorless measurement:

- Use a real-time system to monitor the recorded points and lines for verification of the measurement results
- Use a card target for edges; this will improve precision when measuring to edges as it will resolve split beam ambiguities
- Keep the range and obliqueness to a minimum
- Make overlapping observations separated by layer from one instrument set up to the next as a check against height error.

## DATA LOGGING METHODS

Data logging methods can be divided into two types:

- *Post-process:* Post-process data logging is typically used for DTMs and control work at scales between 1:500 and 1:2500. If rapid capture and field equipment survival are more important than detailed verification, a post process approach will give the benefit of robust field kit and speed of capture.
- *Real-time CAD:* This is a method of digitising 3-D data from the instrument directly into a CAD environment.

The use of real-time CAD capture is of great benefit for large-scale close range work, such as the recording of detail for historic building surveys. When used with reflectorless instruments surveyors can edit and complete data in CAD at the point of capture. Close range reflectorless work, such as internal building survey, is best recorded by real-time CAD.

## WORKING WITH REAL-TIME CAD

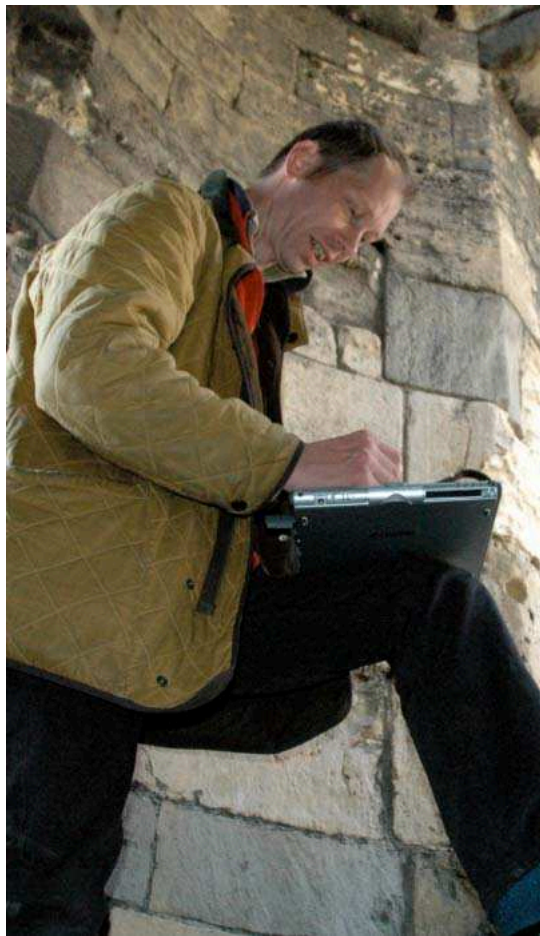

Data loggers differ for post-fieldwork processing (post-process) or real-time data capture.

### POST-PROCESS LOGGERS

Post-process loggers are tough and have low power requirements. Data is viewed via a small screen on the logger in the field, sometimes with a limited graphical function, but usually as lists of observations. Data loggers for post-process survey commonly employ field codes attached to observations by the operator as a means of data separation and definition e.g. to identify line type, feature type, line start/stop etc. Many instruments are supplied with sufficient on-board memory to make the post-process logger redundant. The major shortcoming of the post-process method is that mistakes cannot be easily detected and remedied on site – if errors are detected, the relevant detail must be resurveyed the following day. This can be problematic in situations where site access is limited.

### REAL-TIME DATA LOGGERS

In contrast to the post-process method, an EDM can be used directly with CAD, using software that provides an interface between survey instruments and data loggers, allowing survey

**Fig 3.5 TABLET PCs & THE DIGITAL WORKFLOW:** Real-time CAD capture of EDM work improves the speed and quality of point selection and taking the CAD work to the site improves the presentation of CAD work. To date PDA alternatives lack this flexibility. There is a balance between the cost of using a PC as field equipment and the speed and quality gained by using a 'direct to CAD' method. The vulnerability of direct survey methods to errors in selection and presentation of measured data can be ameliorated by using real-time field CAD but this is at the cost of specialised items like tablet PCs, software and the requisite skills to use them.

data to be recorded in real-time. The surveyor can then draw detail using the EDM to position points and lines in the 3D CAD drawing. The product can be a 3D wire-frame to be used as an outline for future hand survey or a complete drawing. Some survey practitioners use small devices such as PDAs for recording real time data. These have some advantages over the post-process data logger:

Advantage	Disadvantage
Graphical interface	Ruggedness is compromised
Portability	The graphical interface is limited by size and resolution
Low cost	Processing power and memory is heavily compromised
Small size	CAD software for PDA platforms is limited in functionality and not CAD industry standard : a 2 <sup>nd</sup> and 3 <sup>rd</sup> step in the 'field to finish' workflow is introduced

To get the most out of real-time CAD a field computer is required. The best are those that use a pen interface and have daylight readable screens. These are more costly than a standard laptop or PDA and may need external power from spare batteries. Weather protection is a must and all cables will need to be of a robust quality. Ruggedised computers vary widely in specification and performance; it is important to check carefully details like data exchange, power supply and screen performance before choosing a field unit. It must be able to run an industry standard CAD application such as AutoCAD® or Microstation® to get the full benefits of using CAD functionality in the field. Living with a computer in the field can be demanding on both the user and the hardware; a safe mounting bracket is a wise investment as it will save a computer from costly damage and will improve the field working environment for the surveyor.

### PROS AND CONS OF REAL-TIME FIELD C A D

Tracing with an EDM into CAD is rapid. The density of points can be matched to the required presentation standard and the quality of the work checked at capture. CAD edits made on site (such as offsetting lines for details, closing shapes and using fillet, extend and trim) can be effective but a balance must be made with photographing or sketching detail for later CAD work up. Setting up views of sectional elevations from a wire frame can help in the selection of detail to be included and is vital in elevation work. Data can be separated and edited by layer for line weight and type rather than by the alternative coding method. Full size details can be worked up in CAD off-site and then fitted to precise 3D positions using wire-frame.

### CHECKING DRAWING QUALITY WITH FIELD C A D

There is a significant advantage in taking CAD to the site rather than taking work from the site to CAD, as selection and presentation issues can be resolved on site and layering can be organised easily. EDM data is particularly prone to poor line quality: choosing appropriate point density is a matter of skill and this is something that is best checked at the point of capture. The conventions of the drawing can be tested against the site at capture to resolve ambiguities of line weight etc. When using a direct technique like EDM, confidence in data selection is important: it will be the only information that is transmitted, and therefore verifying the selection of points and their correct presentation is vital. The guidance offered is based on practical experience: the outcomes from survey have a theoretical basis but it should be remembered that survey is a practical art and has long been recognised as such. The plans of a large building comprising many rooms on several floors should not be attempted without a series of reliable control points linked together by a traverse.

### CONTROL IS THE PRECISE FRAMEWORK FOR LINKING SURVEY TOGETHER

Control measurements underpin the precision of the whole survey, so control data will be determined to a higher order of precision than that used for detail. EDM is an ideal tool for the control of small sites as it is precise and flexible. Using methods like traversing, the precision of computed positions is raised above that of radial detail shots. Although most control for building survey is undertaken using an EDM, GPS can supply data to high orders of precision for larger sites, but its application is restricted by the need for a clear view of an open sky. Control methods are often specific to particular survey types, scale and speed of work.

The control methods described here are:

- EDM Traverse: in the following section a manual method of traverse computation is described, there are many software tools for the computation of traverses but the example shown can be used to demonstrate the theory and practise of adjustment. Sufficient information is given to carry out a traverse and the necessary adjustment computations. Traversing is the most widely applicable method of achieving precise control on a site.
- EDM resection from 3D detail points is described below in the first case study (p 44). Resection is a method of determining station position by measurement to a minimum of 2 other positions with known 3D coordinates. It is a very effective method of achieving rapid positioning when working in confined spaces.



**Fig 3.6 SEEING THE PLOTTED WORK AS IT'S MEASURED**

Using a tablet PC to monitor EDM work is the best way to map internal building spaces: the real-time CAD plot enables feature selection and point density to be matched to the drawing requirements.

## 1. PLACE THE TRIPOD OVER THE POINT

Find the marked station from which you will work. Release the leg adjustment screws of the tripod legs, pull the tripod stage plate up to your chin and tighten them again. Open the legs of the tripod out to a diameter of over 1m and eye through the centre of the top to ensure it is sitting over the station. Level the top of the tripod by eye. Place the tribrach and theodolite onto the tripod and tighten the fixing screw.

## 2. CENTRE THE TRIBRACH

Use the plummet to move the set up over the point: lift two tripod legs and rotate about the third to get over the point. When using an optical plummet place your foot over the mark to help you find it and move the instrument and tripod together until it is over the station. Firm in the feet of the tripod. Drive the centre of the plummet to the centre of the mark using the thumbscrews on the tribrach: work on 2 screws by turning them in opposite directions (thumbs in or thumbs out) and then the third screw alone. Watch the mark move and adjust accordingly.

## 3. LEVEL UP THE SET-UP

- **A - COARSE ADJUSTMENT: TRIBRACH BUBBLE** Adjust whichever leg the bubble on the tribrach is in line with by using the leg adjustment clamp to push the bubble more to the middle or to another leg. Adjust the legs in turn until the bubble sits exactly in the middle.
- **B - FINE ADJUSTMENT: PLUMMET** Use the tribrach thumbscrews to bring the plummet back on to the station mark then readjust the tripod legs to bring the bubble back to level.
- **C - FINE ADJUSTMENT: TRIBRACH BUBBLE** Press the spirit level button on the theodolite to view the fine tuning screen. Turn the screen to sit parallel with two foot-screws of the tribrach. Using both thumbs, in opposite directions to each other, turn the two thumbscrews until the horizontal bar is level. Turn the back thumbscrew by itself until the vertical bar is level. A small displacement of the plummet mark can be corrected by gently loosening the tribrach fixing screw and sliding the tribrach and theodolite until it sits directly over the station. Check the fixing screw is tightened securely, the bubble is centred and the plummet is over the mark before any measurement is made.

Fig 3.7.1: Far right: from top: 1- Mount the instrument on the tripod. 2- centre the tripod & instrument over the mark. 3- centre the plummet with the tribrach foot screw, level the tribrach bubble using the tripod leg adjustment.

Fig 3.7.2 Right: from top: 1- The tribrach foot-screws are used 2 and 1 by turning the 2 screws 'thumbs out' or 'thumbs in' - never both thumbs in the same direction! 2- Levelling with the leg adjustment. 3- grip the tripod leg as shown and slide each leg in turn up or down as required to level the bubble. 4, 5- Bring the plummet back over the mark with the foot screws.

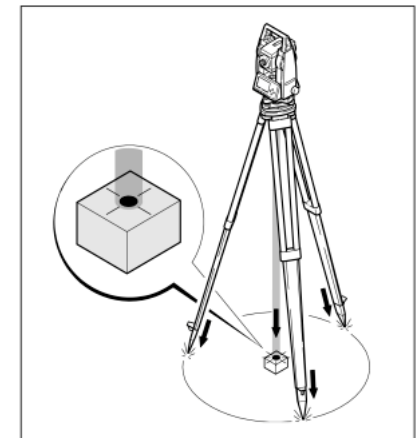

## STARTING CONTROL

The purpose of a traverse is to locate points relative to each other on a common grid. Surveyors need certain elements of starting data, such as the co-ordinates of a starting point and an azimuth to an azimuth mark. There are several ways to obtain the starting data, and surveyors should make an effort to use the best data available to begin a traverse. Survey-control data is available in the form of existing stations (with the station data published in a list or schedule) or new stations (established by local agencies who can provide the station data).

## OPEN TRAVERSE

An open traverse (Fig 3.8) originates at a starting station, proceeds to its destination, and ends at a station with an unknown relative position. The open traverse is the least desirable traverse type, because it does not provide the opportunity for checking the accuracy of the fieldwork. All measurements must be carefully collected, and every procedure for checking position and direction must be used. Therefore, the planning of a traverse should always provide for closure of the traverse.

## CLOSED TRAVERSE

A closed traverse either begins and ends on the same point (i.e. a loop traverse, Fig 3.9) or begins and ends at points with previously determined (and verified) co-ordinates (i.e. a link traverse, which could also look like Fig 3.8). In both cases, the angles can be closed and closure accuracy can be mathematically determined.

## TRAVERSE CLOSED ON A STARTING POINT

A traverse that starts at a given point, proceeds to its destination, and returns to the starting point without crossing itself in the process is referred to as a loop traverse (Fig 3.9). Surveyors use

this type of traverse to provide control if there is little existing control in the area and only the relative position of the points is required. While the loop traverse provides some check of the fieldwork and computations, it does not ensure the detection of all the systematic errors that may occur in a survey.

## TRAVERSE CLOSED ON A SECOND KNOWN POINT

A traverse that is closed on a second known point begins at a point of known co-ordinates, moves through the required point(s), and terminates at a second point of known co-ordinates. Surveyors prefer this type of traverse because it provides a check on the fieldwork, computations, and starting data. It also provides a basis for comparing data to determine the overall accuracy of the work.

## FIELDWORK

In a traverse, three stations are considered to be of immediate significance. These stations are the rear (*back*), the occupied (*current*), and the forward (*fore*). The rear station is the station that the surveyors who are performing the traverse have just moved from, or it is a point to which the azimuth is known. The occupied station is the station at which the party is located and over which the instrument is set. The forward station is the immediate destination of the party or the next station in succession.

## HORIZONTAL ANGLES

Always measure horizontal angles at the occupied station by sighting the instrument at the rear station and measuring the clockwise angles to the forward station. Make instrument observations to the clearest and most defined and repeatable point of the target that marks the rear and forward stations. Measurements are repeated according to the required specifications.

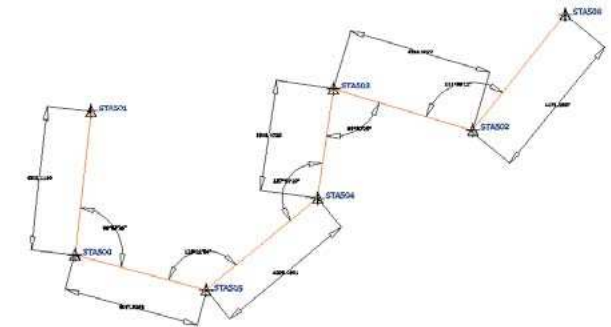
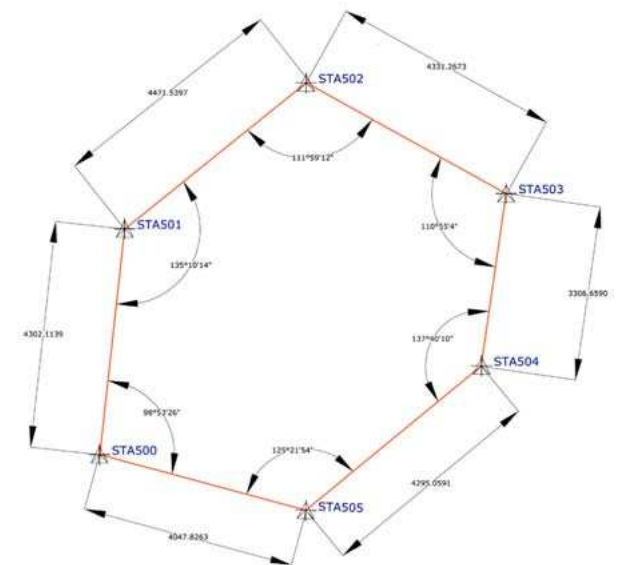

Fig 3.8 Link Traverse. If only the starting point is known, this is considered an open traverse. If both the start and endpoints are known, this is considered a closed traverse. Open traverses have no check on the position of the computed station positions.

Fig 3.9 This is a loop traverse and by its nature, must be a closed traverse.





## DISTANCE

Use an EDM to measure the distance in a straight line between the occupied and the forward stations. Measurements are repeated according to the required specifications. The simplest method of resolving traverses will require a computed horizontal distance to derive 2D co-ordinates for the station values: be aware that most survey instruments measure a slope distance. A correction for slope can be applied if the vertical angle and height of instrument and target is recorded for each shot.

## TRAVERSE STATIONS

Select sites for traverse stations as the traverse progresses. Locate the stations in such a way that at any one station both the rear and forward stations are visible. The number of stations in a traverse should be kept to a minimum to reduce the accumulation of instrument errors and the amount of computing required. Short traverse legs (sections) require the establishment and use of a greater number of stations and may cause disproportionate errors in angular measurement. Small errors in centring the instrument, in station-marking and in instrument pointing are magnified and absorbed in the azimuth closure as errors in angle measurement.

## STATION MARKERS

Station markers need to be securely fixed. They must be clearly marked with the centre point to designate the exact point of reference for angle and distance measurements. To assist in re-occupation, surveyors prepare a reference document (witness diagram) showing the station location relative to a minimum of 3 survivable marks. When working in heritage places it is important to consider the impact of survey marks on the fabric of the monument.

## STATIONS AND TARGETS

Targets must be erected over survey stations to provide a sighting point for the instrument operator. The survey target prism set is the most commonly used signal. A traversing set comprising 3 tripods, 3 inter-changeable tribrachs, 2 matched prisms and an EDM with data logger should be used.

## TRAVERSE TEAM ORGANIZATION

The number of personnel available to perform survey operations depends on the resources available and the size of the territory to be covered. The organisation and duties of a traverse party are based on the functional requirements of the traverse. The lead surveyor selects and marks the traverse-station locations and supervises the work of the other party members. The lead surveyor also assists in the survey reconnaissance and planning. At a minimum the traverse team should be competent at setting up an instrument or target over a point and understand the necessity of recording all data associated with this action. An understanding between operators of what to move and when it's safe to do so is required for the traverse to succeed.

TRAVERSE OPERATIONS consist of the following tasks:

**Instrument operation.** The instrument operator measures the horizontal angles and distances at each traverse station.

**Booking.** If working manually field notes are booked in a notebook and a record is made of the angles and distances measured by the instrument operator as well as all other information pertaining to the survey.

**Setting out and minding targets** involves marking and witnessing the traverse stations, removing the target from the rear station when signalled by the instrument operator, and moving the target forward to the next station.

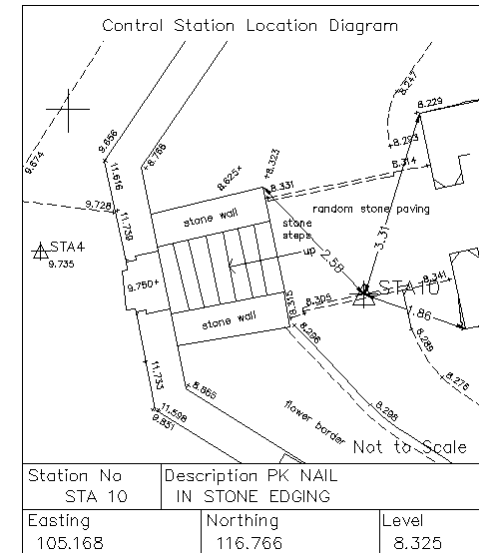

Fig 3.10 Witnessing Diagram.

On setting up a station, the location of the mark must be recorded for future reference. The effort required to derive a precise position for the station is wasted if it cannot be recovered!



Fig 3.11 Station Markers: a selection of marks is usually needed. Parker-Kalon (PK) masonry nails are good for marks in masonry or tarmac. A clear centre mark is essential.

### OBSERVATION PROCEDURE

Traverse observations should follow a strict procedure: angles turned in the same direction and taken in sets. A round of angles describes the turning of the horizontal angle and a 'set' is the data from 2 rounds, one taken on each face of the instrument. At each set up the surveyor should make sure the angles are booked securely and check the sets are complete (including the instrument and target heights) before moving on.

If the traverse is manually booked make use of a prepared observation form so that each angle and distance is recorded so that it can be clearly identified with the occupied station, target stations and the heights thereof.

### TRAVERSE COMPUTATION

A traverse adjustment is based on the assumption that errors have accumulated gradually and systematically throughout the

traverse. The correction is distributed among the angles of the traverse. The computation is best dealt with as a form in which the field information is tabulated for clarity. Traditionally traverses are computed as 2D (x,y) data and the heights (z) computed separately from the vertical angle and slope distance data. It is common practise to level the heights of the stations as a separate exercise.



Fig 3.12

Changing face or transiting the telescope to change instrument faces: by using both faces of the instrument for each round of observations the precision of the observed angles is improved by balancing centering errors.

#### Traverse Field Booking Form

Site: *Oxford Newey line* Surveyor: *Wb* Date: *14.2.02* Weather: *Drizzle* Page: *①*

Inst. @ Stn.	Height of Collimation	To target @ Stn.	Height of Collimation	Horizontal Angle		Vertical Angle		Distance	
				Face 1	Face 2	Face 1	Face 2	Face 1	Face 2
<i>RO =</i>		<i>144</i>	<i>14'05"</i>	<i>@ 1</i>					
<i>2</i>	<i>1.556</i>	<i>1</i>	<i>1.438</i>	<i>259°17'43"</i>	<i>79°17'47"</i>	<i>86°43'22"</i>	<i>266°43'20"</i>	<i>29.021</i>	<i>29.022</i>
		<i>3</i>	<i>1.562</i>	<i>84°50'18"</i>	<i>264°50'18"</i>	<i>92°55'15"</i>	<i>272°55'15"</i>	<i>11.545</i>	<i>11.545</i>
		<i>1</i>	<i>1.438</i>	<i>259°17'40"</i>	<i>79°17'42"</i>	<i>86°43'30"</i>	<i>266°43'15"</i>		
		<i>3</i>	<i>1.562</i>	<i>84°50'22"</i>	<i>264°50'10"</i>	<i>92°55'17"</i>	<i>272°55'17"</i>		
<i>3</i>	<i>1.562</i>	<i>2</i>	<i>1.556</i>	<i>160°34'20"</i>	<i>340°34'18"</i>	<i>02°55'17"</i>	<i>182°55'20"</i>	<i>11.543</i>	<i>11.545</i>
		<i>4</i>	<i>1.572</i>	<i>186°34'10"</i>	<i>06°34'20"</i>	<i>85°40'06"</i>	<i>269°40'07"</i>	<i>5.576</i>	<i>5.577</i>
		<i>2</i>	<i>1.556</i>	<i>160°34'15"</i>	<i>340°34'20"</i>	<i>02°55'10"</i>	<i>182°55'18"</i>		
		<i>4</i>	<i>1.572</i>	<i>186°34'19"</i>	<i>06°34'17"</i>	<i>85°40'05"</i>	<i>269°40'09"</i>		
<i>4</i>	<i>1.572</i>	<i>3</i>	<i>1.562</i>	<i>90°02'24"</i>	<i>270°02'22"</i>	<i>35°08'20"</i>	<i>266°51'30"</i>	<i>5.576</i>	<i>5.575</i>
		<i>5</i>	<i>1.544</i>	<i>189°44'27"</i>	<i>9°44'25"</i>	<i>92°46'25"</i>	<i>272°46'24"</i>	<i>4.584</i>	<i>4.584</i>
<i>5</i>	<i>1.544</i>	<i>4</i>	<i>1.572</i>	<i>148°29'34"</i>	<i>328°29'30"</i>	<i>87°13'29"</i>	<i>267°13'30"</i>	<i>4.584</i>	<i>4.585</i>
		<i>6</i>	<i>1.602</i>	<i>205°29'32"</i>	<i>25°29'34"</i>	<i>90°21'50"</i>	<i>000°24'55"</i>	<i>21.231</i>	<i>21.230</i>

Fig 3.13 TRAVERSE BOOKING SHEET

Tabulated booking sheet for traversing showing the booking of face 1 and face 2 observations. The order of the table matches the order of the observations, station and target heights, horizontal angle, vertical angle and slope distance. The table has columns for multiple observations using both faces of the instrument. The observation to the reference object for the orientation of the traverse is clearly identified as 'RO'. Where an observation field is not recorded a null entry is made to confirm the action is carried out and that the entry has not been omitted. (In this example repetition of the distance measurements was not made on the 2nd face observations). All traverse observation records must show the identity of the surveyor, the site name and the date of the survey operation.

Fig 3.14 TABULATED COMPUTATION OF TRAVERSE OBSERVATIONS: worked example.

Sta	Leg	Hz Dist(m) <sup>1</sup>	Observed Angle(d.m.s) <sup>2</sup>	Angular Adj <sup>3</sup>	WCB (d,m,s) <sup>4</sup>	Partial co-ordinates <sup>5</sup>				Linear 6 (Bowditch) Adj.		Final co-ordinates		Sta
						$\Delta E (s \sin a)$	$\Delta N (s \cos a)$	E	N	E	N			
<b>RO - Sta 08</b>			144.19.05											
01			118.13.09	+2"								1000.000	1000.000	01
	01-02	24.021			262.35.15		23.820		3.098	-0.005	-0.003			
02			186.32.36	+2"								976.180	996.9029	02
	02-03	11.550			269.04.51		11.548		0.185	-0.002	-0.001			
03			259.11.26	+2"								964.632	996.717	03
	03-04	5.576			348.16.17		1.133	5.459		-0.001	-0.000			
04			99.42.03	+3"								963.499	1002.176	04
	04-05	4.585			267.58.20		4.582		0.162	-0.000	-0.000			
05			95.48.37	+3"								958.917	1002.014	05
	05-06	21.231			183.47.17		1.403		21.185	-0.003	-0.002			
06			89.58.15	+3"								957.514	980.8292	06
	06-07	19.652			93.45.33	19.609			1.288	-0.004	-0.002			
07			170.07.14	+3"								977.123	979.541	07
	07-08	35.094			83.52.47	34.894	3.741			-0.007	-0.004			
08			60.26.19	+3"								1012.017	983.282	08
	08-01	20.607			324.19.05		12.019	16.738		-0.004	-0.002	999.998	1000.020	
												1000.000	1000.000	01
$\Sigma$		142.316	1079.59.39	21"		54.503	54.547	25.938	25.918					
Angle Sum			1080.00.00		Distance Misclosure:	$\Sigma \Delta E$ -0.030		$\Sigma \Delta N$ -0.020						
Angular Misclosure:			000.00.21"		Total Misclosure:			0.102						
Precision:														

Notes:

- 1 The horizontal distance. Most EDM units will report the slope distance so the Horizontal distance will have to be calculated from the slope distance and vertical angles for each leg
- 2 This is the mean of the angles observed at each station
- 3 The adjustment is distributed using whole seconds by size
4. The whole circle bearing is effectively the direction from one station to the next relative to the RO (in this case North)

### ANGLE SUM

If the mean observed angles are reduced to the internal angles of a polygon (Fig 3.15) a check can be made on the required total. The angle sum will indicate the required total angle for a given number of angles in a polygon. The internal angles of the figure will sum to:

$$(2n - 4) \times 90^\circ$$

and the exterior:

$$(2n + 4) \times 90^\circ$$

Where n= the number of angles in the polygon. The difference between the angle sum required and the measured angle is the angular misclosure.

Stn	Mean measured angle
A	101° 28' 00"
B	102° 11' 00"
C	104° 42' 00"
D	113° 05' 00"
E	118° 34' 00"
Angle Sum: measured	538° 00' 00"
Angle Sum: expected	540° 00' 00"
<b>Angular misclosure</b>	<b>-02° 00' 00"</b>

The angular misclosure is distributed equally between the station angles and tabulated. The adjusted angles can now be carried forward to the calculation of the whole circle bearings between the stations.

Fig 3.16

THE WHOLE CIRCLE BEARING (in red) is the direction component derived from the starting orientation of the traverse. The internal angle at each station is taken and used to calculate the whole circle bearing.

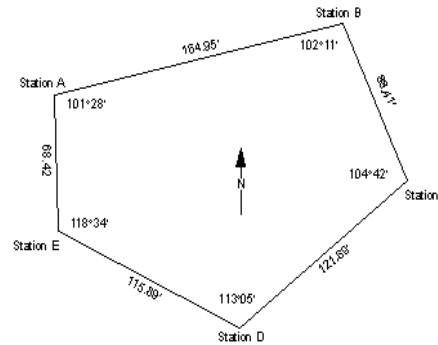
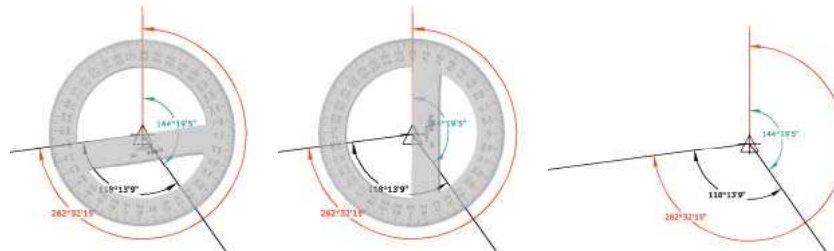

Figure 3.15 Closed polygon

### WHOLE CIRCLE BEARING (WCB)

(at '4' in the worked example)

After the angles are adjusted, compute the adjusted whole circle bearing (azimuth) of each leg by using the starting bearing and the adjusted angles at each traverse station. Carry the adjusted bearing throughout the entire traverse and then check it against the observed closing bearing before beginning any further traverse computations.

### TRIGONOMETRIC TOOLS

To determine the co-ordinates of the traverse stations the trigonometric functions sine (denoted by *sin*) and cosine (denoted by *cos*) are used. It is useful to remember how the trig functions are derived when using them as a check on misapplication:  $\text{Sin}=\text{O}/\text{H}$ ,  $\text{Cos}=\text{A}/\text{H}$  and  $\text{T}=\text{O}/\text{A}$  are the basics.

### PARTIAL CO-ORDINATE COMPUTATIONS

(at '5' in the worked example)

1. If the co-ordinate of a point and the bearing and distance from that point to a second point are known, the co-ordinate of the second point can be computed. The azimuth and distance from Station A to Station B are determined by measuring the horizontal angle from the azimuth mark to Station B and the distance from Station A to Station B.
2. A grid is a rectangular system with the Easting and the Northing lines forming right angles at the point of intersection. The computation of the difference in the difference in Easting ( $\Delta E$ ) (side X) and Northing ( $\Delta N$ ) (side Y) requires the computation of a right angled triangle. The distance from Station A to Station B is the hypotenuse of the triangle, and the bearing angle (azimuth) is the known angle. The following formulae are used to compute  $\Delta E$  and  $\Delta N$ :
 
$$\Delta E = \sin WCB \times \text{horizontal distance}$$

and

$$\Delta N = \cos WCB \times \text{horizontal distance}$$
3. If the traverse leg falls in the first (North-East) quadrant, the value of the Easting increases as the line goes east and the value of the northing increases as it goes north. The product of the  $\Delta E$  and the  $\Delta N$  are positive and are added to the easting and northing of Station A to obtain the co-ordinate of Station B.

4. When using trigonometric calculators to compute a traverse, enter the WCB angle, and the calculator will provide the correct sign of the function and the  $\Delta E$  and the  $\Delta N$ . If the functions are taken from tables, the computer provides the sign of the function based on the quadrant. Lines going east have positive  $\Delta E$ s; lines going west have negative  $\Delta E$ s. Lines going north have positive  $\Delta N$ s; lines going south have negative  $\Delta N$ s.

5. The following are examples of how to determine the  $\Delta N$  and the  $\Delta E$ :

- Given a whole circle bearing between Station A to Station B of  $70^{\circ}15'15''$  and a distance of 568.78 meters (this falls in the first [NE] quadrant), compute the  $\Delta E$  and the  $\Delta N$ .

$$\Delta E = \sin 70^{\circ}15'15'' \times 568.78 = +0.941200 \times 568.78 = +535.34 \text{ m}$$

$$\Delta N = \cos 70^{\circ}15'15'' \times 568.78 = +0.337848 \times 568.78 = +192.16 \text{ m}$$

- Given a whole circle bearing from Station B to Station C of  $161^{\circ}12'30''$  and a distance of 548.74 meters (this falls in the second [South-East] quadrant), compute the  $\Delta E$  and the  $\Delta N$ .

$$\Delta E = \sin 161^{\circ}12'30'' \times 548.74 = +0.322128 \times 548.74 = +176.76 \text{ m}$$

$$\Delta N = \cos 161^{\circ}12'30'' \times 548.74 = -0.946696 \times 548.74 = -519.49 \text{ m}$$

- Given a whole circle bearing from Station C to Station A of  $294^{\circ}40'45''$  and a distance of 783.74 meters (this falls in the fourth [North-West] quadrant), compute the  $\Delta E$  and the  $\Delta N$ .

$$\Delta E = \sin 294^{\circ}40'45'' \times 783.74 = -0.908660 \times 783.74 = -712.15 \text{ m}$$

$$\Delta N = \cos 294^{\circ}40'45'' \times 783.74 = +0.417537 \times 783.74 = +327.24 \text{ m}$$

## ADJUSTMENT OF DISTANCE MISCLOSURE

(at '6' in the worked example)

The distribution of the difference between the computed co-ordinates measured in the traverse and the expected co-ordinate position of the known point(s) is the 2<sup>nd</sup> step in resolving the final co-ordinates of the traverse stations. The distance error will be in 2 components: a displacement in

Easting and a displacement in Northing. If it is assumed that the distance errors present have propagated over the entire course of the traverse, a proportional distribution of the error to each leg can be applied. The standard method of proportional distance error distribution for traverses is the **Bowditch adjustment** (Fig 3.14). The Bowditch adjustment simply distributes the misclosure (in the first case in Easting, then the Northing) by the leg length over the total distance of the traverse. This correction is then applied to each of the partial co-ordinates derived at '25' above. The Bowditch distribution is as follows :

$$(s \times \sum \Delta E) / \sum s \text{ for each leg Easting}$$

and

$$(s \times \sum \Delta N) / \sum s \text{ for each leg Northing}$$

where:

$s$  = the horizontal distance of the leg,

$\sum s$  = the total horizontal distance run.

$\sum \Delta E$  = the total distance misclosure in Easting

$\sum \Delta N$  = the total distance misclosure in Northing.

Height calculation is possible from the vertical angle observations: it is common practise to level the traverse stations as a separate exercise to derive heights but also a simple transfer of height by trig using the distances, instrument /target heights and the vertical angle data can be used.

## ACCURACY AND SPECIFICATIONS

The overall accuracy of a traverse depends on the equipment, the procedures used in the measurements, and the accuracy of the starting and closing data. An accuracy ratio or ratio of closure\* (RC) of 1:5,000 is the minimum accuracy sought in topographic surveying. In obtaining horizontal distances, an accuracy of at least 2 millimetres per 100 meters must be obtained. When using a 1" theodolite, turn the horizontal

angles four positions. Keep an angular closure of 10" per station.

## RATIO OF CLOSURE

The RC determines the traverse accuracy and compares it to established standards. The RC is the ratio of the distance misclosure (after it is reduced to a common ratio and rounded down) to the total length of the traverse. If the RC does not fall within allowable limits, the traverse must be redone. It is very possible that the measured distances are correct and that the error can be attributed to large, compensating angular errors.

## CO-ORDINATE ADJUSTMENT

When adjusting a traverse that starts and ends on two different stations, compute the co-ordinates before the error is determined. The correction (per leg) is determined in the same manner, but it is applied directly to the co-ordinates. The correction to be applied after computing the first leg is equal to the correction computed for the first leg. The correction to be applied after computing the second leg is equal to the correction computed for the first leg plus the correction computed for the second leg. The correction for the third leg equals the correction computed for the first leg plus the correction computed for the second leg plus the correction computed for the third leg and so on throughout the traverse. The final correction must be equal to the total correction required.

Sources for this section on EDM traversing:

US Army Field Manual

3-34.331 TOPOGRAPHIC SURVEYING 16 January 2001 Chapter 6.

<http://cartome.org/FM3-34/Chapter6.htm> (used with kind permission)

**CHURCH OF ST. JOHN THE BAPTIST, INGLESHAM**

REDM, hand-drawing and rectified photography combined to produce two sectional elevations.

As it now stands, the church has remained substantially structurally unaltered since the 16<sup>th</sup> century, although the exterior shows evidence of repairs undertaken over the last 200 years, as well as recent bracing and fixing inside the church to ameliorate the effects of structural movement. The church was declared redundant in 1979 and care vested in the Churches Conservation Trust. The main problem in caring for the church is to preserve what has been called its ‘studied informality’ while arresting the damaging effects of age and weather. Much of the interior is decorated with mural paintings of different periods, in places up to seven layers thick. These include an early 14<sup>th</sup> century doom on the east wall of the north aisle, 15<sup>th</sup> century censuring angels above the chancel arch and 19<sup>th</sup> century texts including the Creed, Lord’s Prayer and Ten Commandments.

**THE SURVEY REQUIREMENT**

Two sectional elevations at a scale of 1:20 were required, to be used as a metric framework for and supplement to a program of rectified photography of wall paintings. Scaffolding and ladders were not to be used inside the church, and no marks or targets could be left on the walls because of the fragility of the wall paintings. Drawing products require a highly selective approach to recording and for this reason ‘direct’ survey methods were those used for the bulk of the recording.

**TECHNIQUES USED**

The techniques employed to generate the final drawings comprised:

- REDM – for the provision of accurate line work covering most of the required elements of the two drawings, including the principal sectional cut-lines through the building, the roof structure and exterior detail. The wire-frame from REDM also acts as a metric framework within which parts of the drawing derived from other methods can be positioned.
- Measured drawing – for sculptural details (e.g. column capitals, elaborately carved woodwork and pews). The depiction of these at a scale of 1:20 requires a degree of edge selection not possible using REDM. Both measured drawing and direct plotting techniques were employed as appropriate.
- Photography – this was the best method for recording relatively flat, repetitive details with well defined edges. Photographs can later be rectified using REDM data as a metric framework, and detail digitised from them at the correct scale and in the correct position. Photography is also unquestionably the best method for recording textural detail.

Survey was undertaken using Leica TCRM 1105 and TCR 405 total stations linked by TheoLt (a real-time interface to AutoCAD®) running on Motion M1300 and WalkAbout Hammerhead field computers.

**CONTROL**

The first stage of the survey was to undertake a traverse around the outside of the church, linked to the interior by spurs shot through door openings in the north and south aisles. Outside the traverse stations were marked with survey pins, whilst on the inside of the church detail points were used (for

example corners of floor slabs, parts of lettering on the same). The observations taken by the instruments during the setting out of the traverse were processed using Geosite Office 3.2 Pro traverse adjustment software, and the adjusted station positions computed. Witness diagrams were created for all stations, supplemented by annotated photographs of some of the interior stations to avoid any possible ambiguities in their identification and subsequent reoccupation.

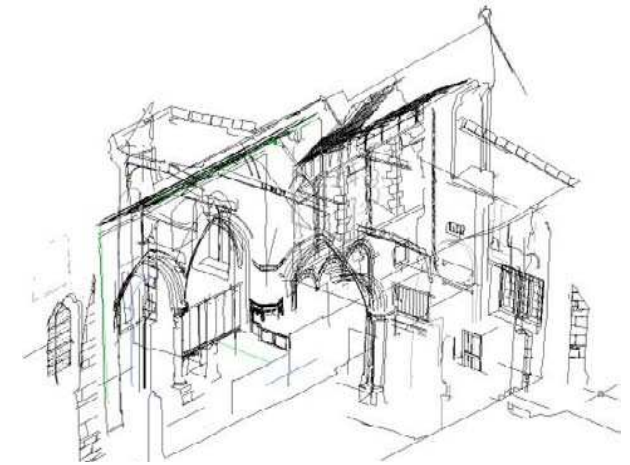

Fig 3.17

**CAPTURED 3D WIRE-F R A M E**

The wire-frame gathered by REDM. Although survey is presented as two ‘flat’ drawings the wire-frame from which the drawings are derived is fully 3D. This allows the work with rectified photography to use 3D detail points as metric constraints. All detail related to major structural elements which appear in the sections, including projected details, windows and roof structure have been mapped. Other features, such as the outlines of the pews in the centre of the nave and some of the ornate wooden screens, have only been mapped in outline. These features are recorded by different techniques and the wire-frame provides positioning for the data derived from these sources. The cut line for the section can be seen running along the floor of the nave.

The stations on the traverse were positioned:

- Where station markers wouldn't be disturbed.
- Where the tripod was generally out of harm's way.
- Where one station was visible from the next.

## SURVEY

Once a control network was in place, much of the REDM survey within the building could be undertaken from 'free' stations, the positions of which were computed by resection to two or more reference points with known co-ordinates in the building. Tripods with prisms can be set up over stations on the traverse and used for resection. At other times it may be necessary to use unambiguous points of detail already in the drawing as resection points (e.g. the head of a nail on a hinge). Changing and re-establishing station position is a quick task with practice, and in building recording it is usually necessary to move the instrument many times to achieve optimum coverage. The free stations used were positioned:

- Where the instrument had an optimum view of the subject. An oblique view usually gives better results than face-on for edges and arrises.
- To minimise laser spillage and avoid two subsequent set-ups to survey an opening, for example.
- To optimise range and angle of EDM incidence: steep shots at long range will fail, so aim to reduce the distance and obliqueness to the target.

Survey started by drawing the principal outlines (cut lines) of

each section through the building, defined by their respective planes. Further line work is then infilled as appropriate. As the output scale was 1:20, considerable care was taken when measuring with the REDM to take points at intervals commensurate with this level of detail.

- Where walls are relatively 'flat' or 'straight', the points can be taken at wider intervals.
- Where the edges curve (for example, when tracing the lines of an arch), points have to be taken at much more frequent intervals in order adequately to express the shape of the object in the drawing at the chosen scale.

Data is separated in CAD using layers to distinguish different elements of the work. Thus, for example, lineweights, cutlines, roof detail, wooden screens, structural elements of nave, aisles, chancel etc. are placed on different, clearly named layers in order to organise the work on site and to make the task of producing the final drawings easier.

Measured drawing was used to record features in the church that were best recorded by this method, for example the fine details of the fixtures and fittings visible in the section. By using the REDM data to locate them, the drawings only needed local control, saving time on setting up plumb and datum lines. The field drawings were digitised and added to the CAD drawing, using the REDM wireframe for position. Field CAD work is separated from other data sources by layer in CAD. Newly added elements of the drawing are inserted on a new layer, named appropriately to record its provenance.

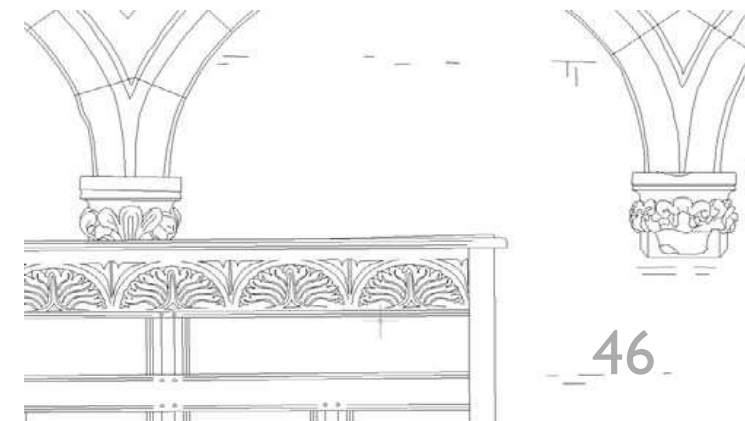
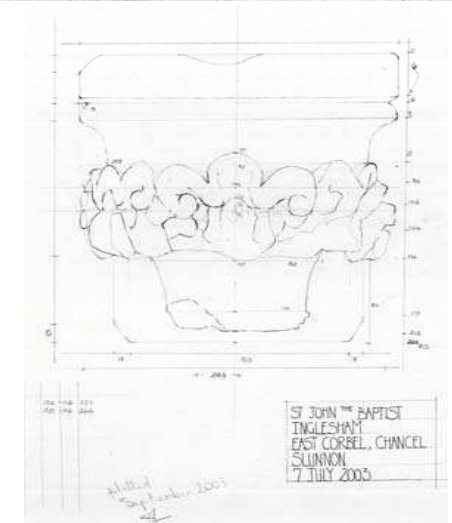
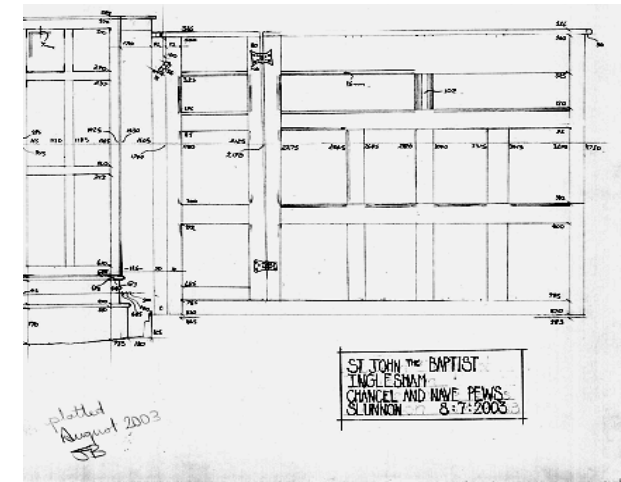
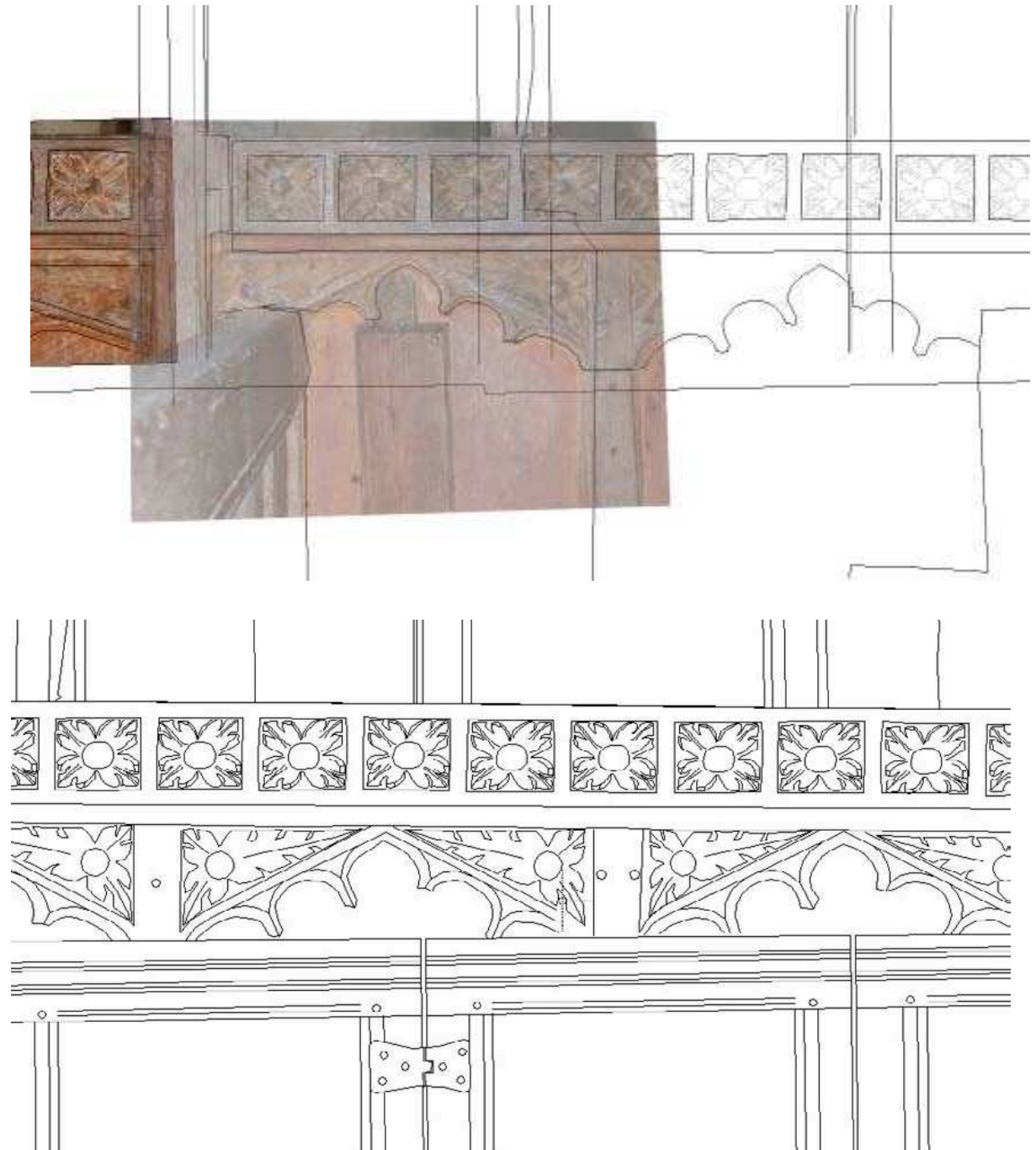

Fig 3.18 MEASURED DRAWINGS were prepared of the fittings and fixtures revealed by the section. The plotted drawings were positioned as 2D blocks in the 3D wire-frame. By using the REDM data for positioning the drawings only local control was needed thus saving time on setting up plumb and datum lines. The final fitted CAD plot of the detail is shown at bottom.

As well as measured drawing, photography can also be used to supplement REDM wireframe. Photographs were taken using a Nikon D70 6.1 MPixel digital SLR, with an output image size of 3008x2000 pixels. In Fig 3.19 a photograph of a part of a carved wooden screen has been rectified to fit the REDM wireframe, and detail can then be traced from the photograph. PhoToPlan (by kubit GmbH) was used for digital rectification in CAD. This allowed on-site rectification of the photographs immediately after they were taken. Note that the rectification is mono-planar, i.e. detail can only be traced reliably from detail in the rectification plane: projecting or recessing detail, such as the back of the pew on the larger photograph above, is subject to distortion, and cannot be used to generate linework.

The balance between techniques used to complement the EDM survey shows how the strengths and weaknesses of different methods can be optimised to generate an integrated CAD product. In Fig 3.20 (2<sup>nd</sup> from left) the REDM acquired wireframe of the capital of one of the columns in the nave is shown. The data is highly positionally accurate, and the points recorded all in their correct 3D positions (as is visible on the right hand side of the picture). It does not, however, describe the form of the capital adequately for reproduction at a scale of 1:20, and the subtlety and flow of the lines used to define the

Fig 3.19 The result of tracing some of this detail from the photographs: it would not be desirable to record this type of detail with REDM, the object size is smaller than the size of the measuring beam and the number of points needed would require the surveyor to spend a great deal of time collecting the data. A simple edge trace can provide an accurate 3D framework for the adding of material from other sources. This part of the drawing also includes (in the lower part of the image) some more pew detail recorded by hand measurement.





# USING REDM & SKETCHING FOR DETAILS

form is not successfully transmitted. The capital was also recorded by sketch, (Fig 3.20, 2<sup>nd</sup> from right) and with photographs. The sketch amplifies edge selection, and shows a more developed method of transmitting the complex 3-dimensional forms of the capital in an intelligible way in 2 dimensions. No other method comes close to the textural richness of the photograph, but the data is undifferentiated. The drawing and the photograph complement each other, and the latter gives confidence in the selection of linework for the former. The measured sketch can then be 'worked up' in CAD, and positioned on a new layer in the drawing using the wire-frame as a metric constraint. The end result of combining the data in this way is shown below (right). The CAD linework digitised from the drawing the drawing is 'flat', but is inserted in the correct position in the wireframe.

## SUMMARY

For the production of 'finished' drawings of a building, no single technique can provide all the answers: REDM generated wireframe forms, as the name implies, a framework which may be used directly for much of the drawing, but which also

constrains and places information derived from other methods. It may be the case that the REDM wireframe is used almost solely for such purposes, for example to constrain photography during rapid survey with limited time available on site, where such methods are commensurate with the brief and required products of the survey.

In the survey of Inglesham Church, data was integrated from five sources:

- EDM control
- REDM wire-frame
- Measured drawing
- Detail Sketch
- Rectified photography

CAD is a good tool for bringing the components together because it is capable of handling 3D vector data well. Line work plotted from measured drawings, traced from photos and worked up from sketches constrained by wire-frame can all be scaled, layered and fitted to the 3D EDM data. CAD is the route from measurement to presentation.

## DETAILING OF CAPITAL

METHOD	USED FOR	REASON FOR CHOICE
Sketch	Clarification of edge selection & form	Selection of edges, transferable to CAD
REDM trace	3D positional accuracy	CAD goal: the position of the subject fixed
Photograph	Site record	Rapid capture of form and texture
Measured drawing	not used	Measurement derived from REDM trace
Rectified photograph	not used	Not a mono-planar subject
Photogrammetry	not used	High cost
Laser scan	not used	High cost

Fig 3 20 RECORDING THE CAPITAL  
From left: Photo, REDM trace, sketch and CAD plot

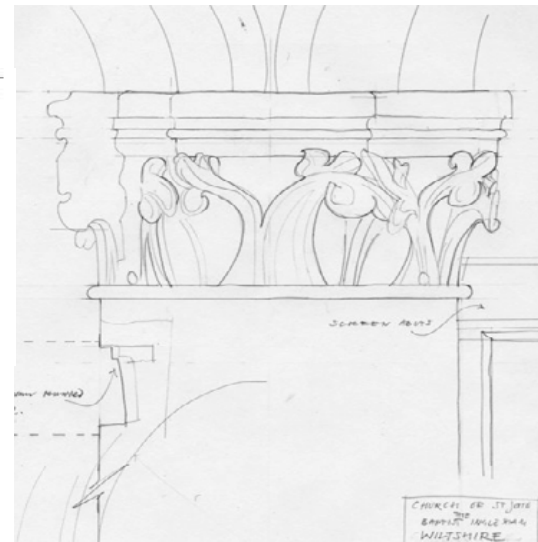
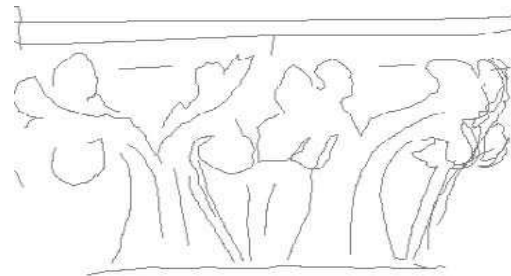



Fig 3.21 The cross section looking East. The section reveals the deformation of the nave arcade and the extent of the wall rotation on the south aisle. Small areas of incomplete detail in the roof voids and at wall plate height were the result of restricted access. The integration of measured drawing, digitised rectified photography and REDM has generated the completeness required for the sectional elevation.

# CHURCH OF ST. JOHN THE BAPTIST INGLESHAM

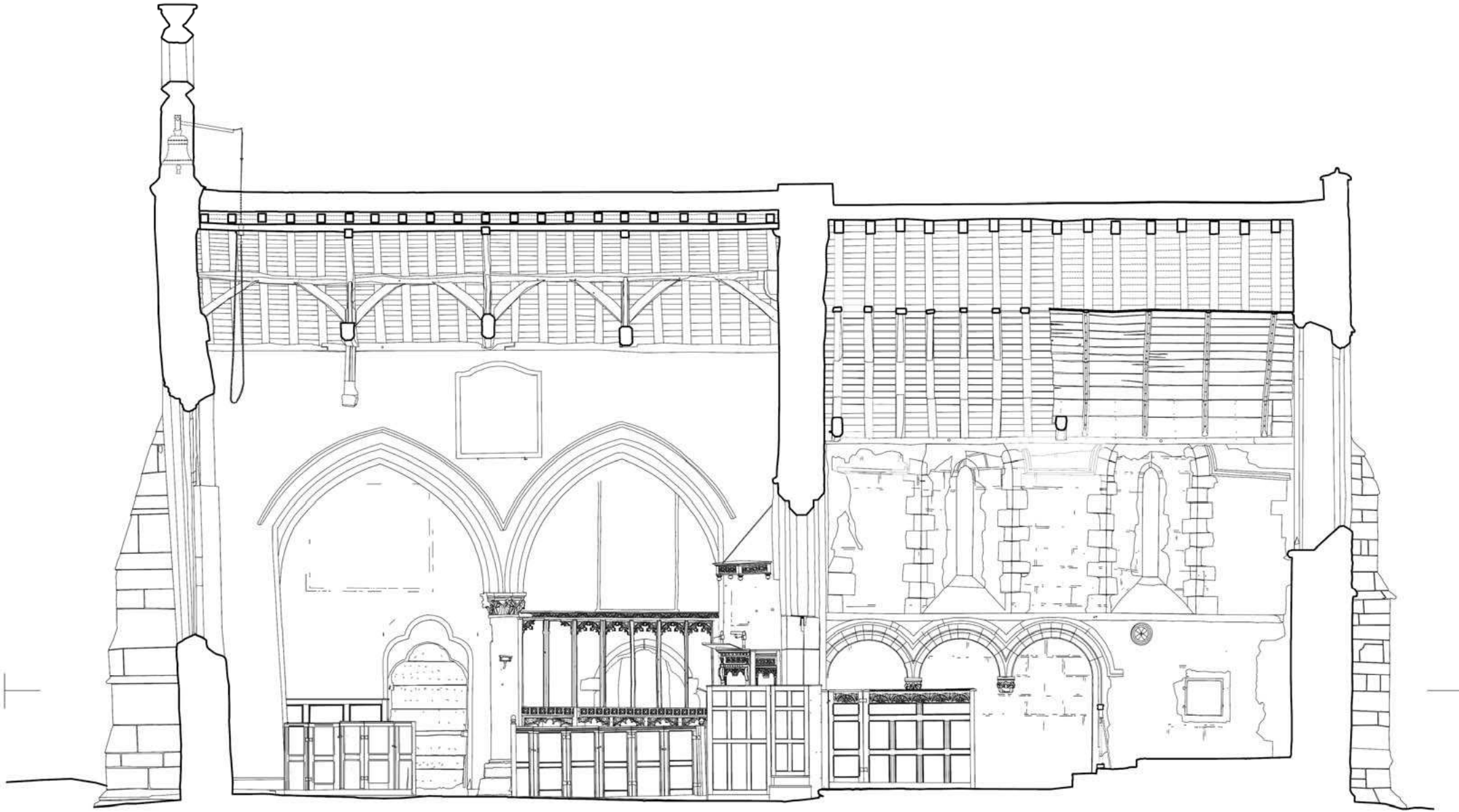

Fig 3.22 The long section looking North. By using the correct combination of drawing , photography and CAD work, the REDM survey records the interior of the church in its current state. The selection of lines and depiction of detail is consistent with the project requirement to provide a 'base map' to plot wall painting conservation works. The inclusion of the furnishings and fittings serves as both a record and a management archive of the condition of these fragile items.

### CHARTLEY CASTLE, STAFFORD

As well as contributing to building survey, EDM can also be used for a number of other applications, such as generating topographic information. Whilst this is useful and important for placing a building or structure in its setting, it is beyond the scope of the present document to discuss this in great detail. An overview of the process and products is given below, with reference to a survey undertaken at Chartley Castle in Stafford.

The survey requirement was to supply the site amangement team with a site plan upon which to plan and record conservation actions and manage visitor access to the site. The suvey was to be used as a site record prior to archaeological investigation.

Whilst most building survey is undertaken using the EDM in reflectorless mode, topographic survey is usually done using IR measurement with a reflective prism on a pole. In this type of survey, two people are usually required, one at the instrument, and the other holding the detail pole, although some of the more expensive surveying instruments permit remote control.

It must be emphasised that using EDM for this kind of work relies on the effective co-operation of the surevyor operating the instrument and the surveyor holding the prism at the point of detail: it is the person with the detail pole who is making the active selection of information. To be effective the survey team must be fully aware of the required selection and depiction requirements of the survey. Useful equipment to have when undertaking this type of survey includes:

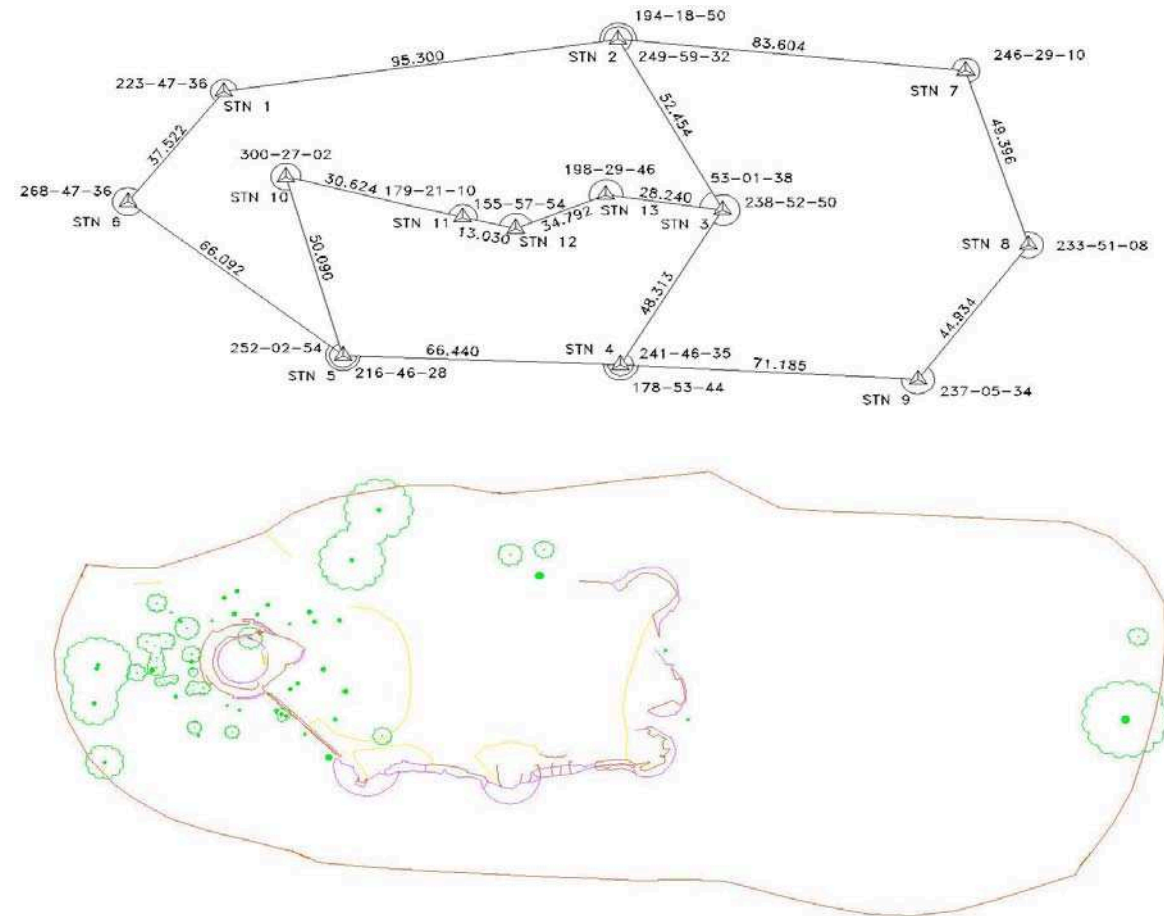

Figs. 3.23 & 3.24 The traverse showing the distribution of controlled stations (above), and (below) the 'hard detail' mapped from the traverse stations.

- a 360° prism (which does not have to be 'aimed' at the instrument)
- walkie-talkies or field radios for communication between operators when at range.

As well as recording the positions of objects in a landscape which have 'hard' edges (e.g. trees, fences, walls etc.), the instrument can also be used to record the general shape of the ground surface, thereby forming a Digital Elevation Model (DEM) of points in 3D space, which can in turn be surfaced and

survey in an ordered state. The illustrations are intended to demonstrate the constituent parts of the survey, all produced on site using EDM.

### CONTROL

First, a traverse is undertaken, as shown (Fig 3.23) with distances and angles clearly indicated. This fundamental part of the survey work should be provided with the finished survey, as illustrated in the final product plan at the end of this section.

### HARD DETAIL

Features forming 'hard detail' may be added, such as wall lines, fences, vegetation (if required) and any other features requiring recording (Fig 3.24).

### DEM

Additionally, break lines can be added. These define sharp changes in slope such as top and bottom edges significant breaks of slope. In this example, the top and bottom edges of ditches and banks have been defined by walking with the detail pole and taking points at intervals appropriate to showing the shapes of the features at the required scale. The break-lines provide the 'skeleton' (Fig 3.25) which defines the properties of the elevation model. In order to fill in the slopes defined by them, additional points are taken as levels. In this example, flatter areas are covered by an approximate grid of points (Fig 3.26), whilst a series of concentric rings have been used to give more information about the slopes of ditches and banks. Where features are more complicated, they may require more points to be taken to elucidate their shape properly. Details not resolved by the DEM are mapped by additional EDM observation or measured drawing so that the information collected is commensurate with the required scale.

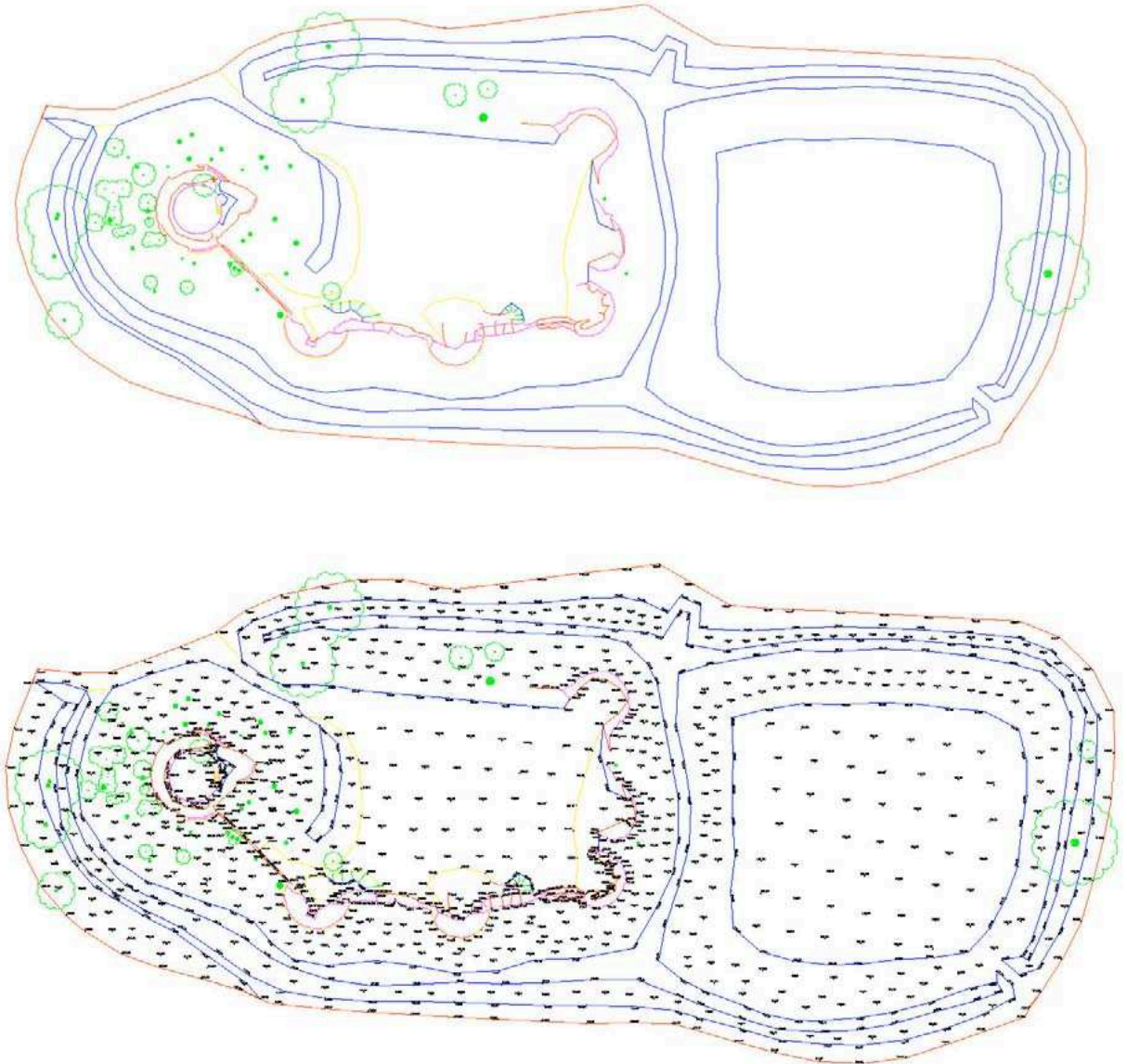

Figs. 3.25 & 3.26 The break lines added and, below, the spot heights showing the distribution used to cover both flat open areas and steep embanked areas

Once the levels and break lines have been surveyed, a Triangulated Irregular Network (TIN) can be generated, linking all the points taken as levels and, depending on the relative level of sophistication of the software employed, taking account of the break lines as well (Fig 3.27). This forms a 3D 'model' of the surfaces recorded, which can be used for a number of purposes. It can usually be converted to a regular grid.

The general approach is to use the elevation model to generate contours as shown in Fig 3.28. Most contouring software permits the specification of contour interval, colour and layer for major and minor contours, labelling options and so forth. Contour models often need to be edited with care after they have been generated in order that they show the forms of the landscape adequately.

## PRODUCT

The finished product, incorporating all of the data surveyed in to one composite plan, is shown below (Figs. 3.29 and 3.30). As well as Eastings and Northings (labelled as tick marks around the edges of the drawing), the traverse diagram is included in the upper left corner, and a co-ordinate schedule for the stations in the traverse included at lower left. A North sign is included, as well as data about the scale of the output, the names of those who undertook and checked the survey, the dates between which the work was undertaken, and a location diagram (if necessary). Some elements of the information may be removed for clarity, such as most of the levels used to generate the elevation model.

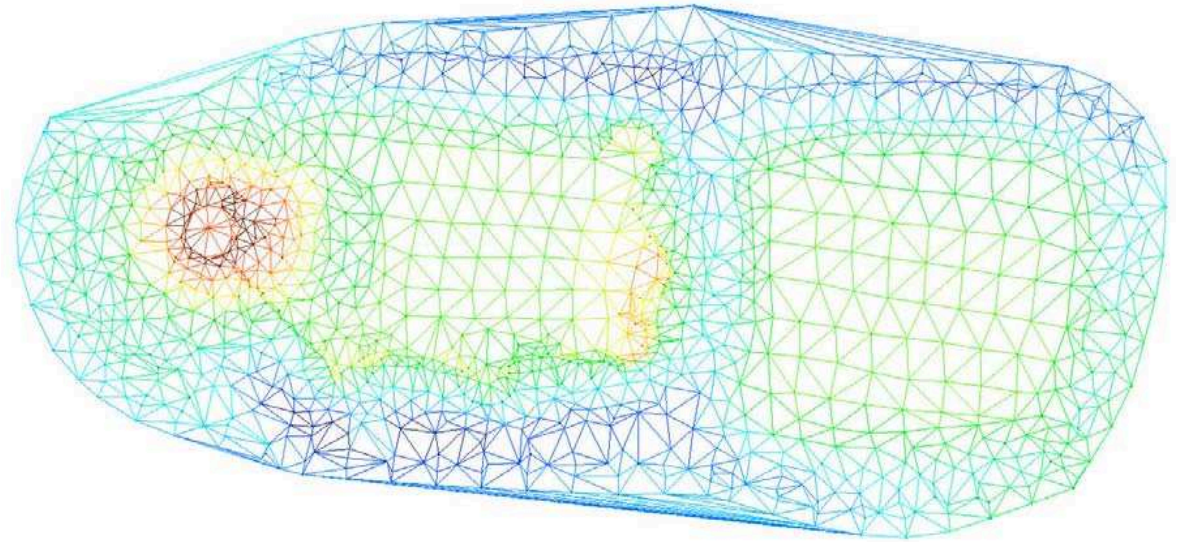

Figs. 3.27 & 3.28 The DEM (top) and the contour model.

Following pages, Figs. 3.29 & 3.30: the plotted survey as presented on the drawing sheet. The monochrome version gives an indication of the line weights used.

# CHARTLEY CASTLE, TOPOGRAPHIC PLAN, 1: 200 SCALE, REDUCED



# CHARTLEY CASTLE, TOPOGRAPHIC PLAN, 1: 200 SCALE, REDUCED

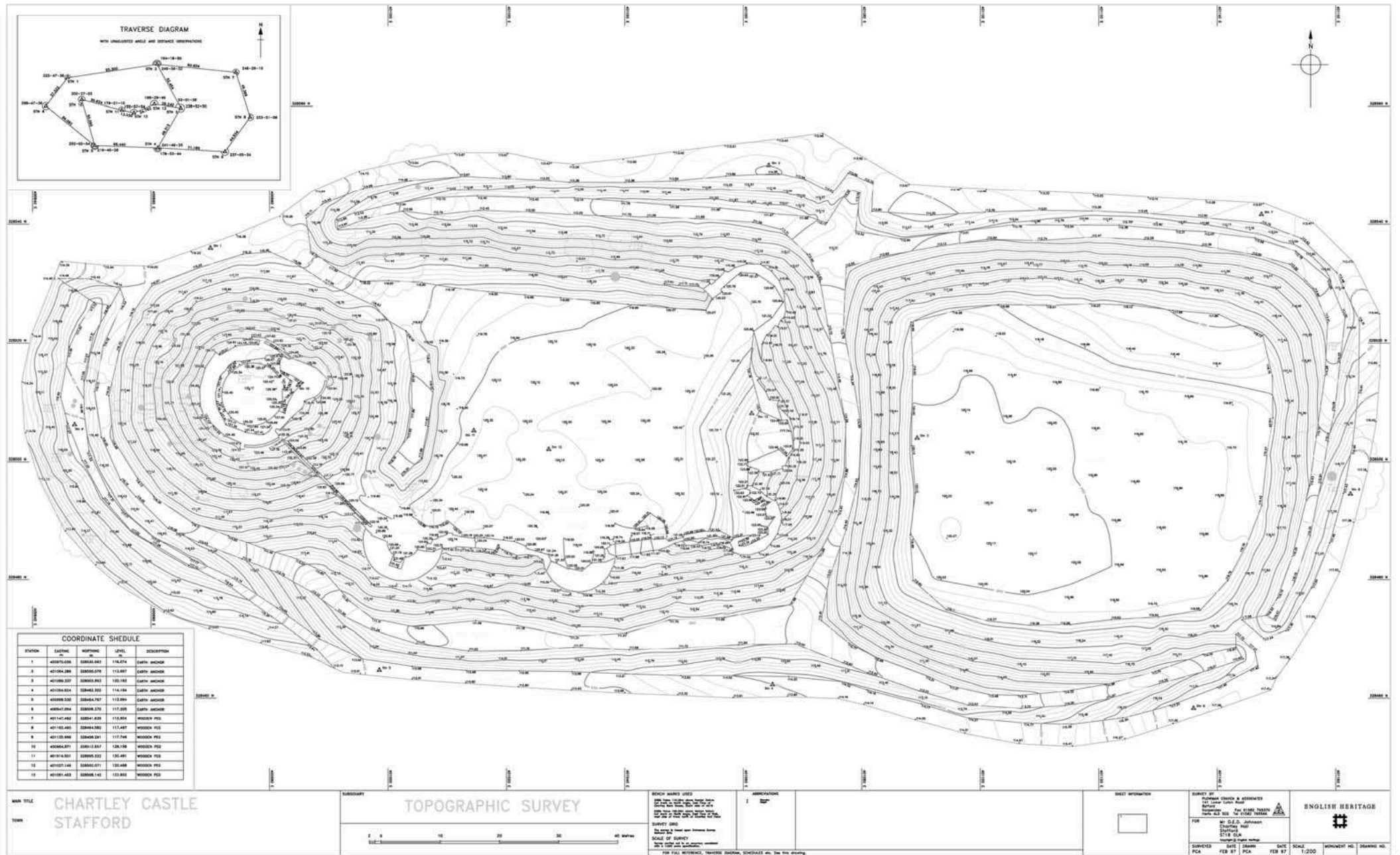





**TRIPOD**

Means of stable support for the EDM unit. Legs are adjustable. A set of 3 are needed for traversing.

**FIELD COMPUTER**

For real-time CAD capture of the instrument data. A mounting bracket should be used to protect the computer and keep the work in view.



**TRIBRACH**

Interchangeable base plate for the EDM and target prism. It is equipped with a bubble to level it. A set of 3 is essential for traversing.



**PRISMS**

A prism is essential for precise measurement in infrared mode for control. There are 4 main types: Mini, circular, 360 and tape.

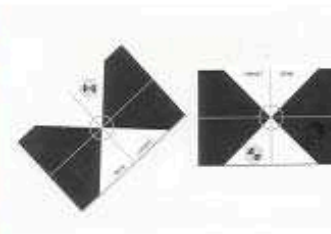

**BUTTERFLY TARGETS**

Used for marking photo-control on façades and control points for reflectorless measurement. Require attachment to the façade using adhesive, so must be used with care.

**PRISM ON DETAIL POLE**  
For shots to ground points and sight lines obstructed for reflectorless measurement. Used vertically as verified by level bubble



**TAPE MEASURE**

For measuring the heights of instrument and target.



**DIAGONAL EYE PIECE**

Adapter for the telescope to enable steep shots: a vital accessory for building work.



**STATION MARKERS**

A variety of marks will be needed for setting out control stations. A perimeter traverse must be securely marked. Internal building survey does not usually permit the use of permanent marks.



**EDM**

Also known as a Total Station Theodolite (TST). Used for measurement of selected angles and distances to targets or points. Consists of a tilting telescope with EDM unit mounted co-axially and 2 circles for the precise measurement of horizontal and vertical angles. Data is recorded either in internal memory, on a data card or an external device such as a field computer or a data logger.



# GLOSSARY OF TERMS FOR EDM SURVEY

As-built survey	Survey recording the building as intended or at an agreed date in its construction.
As-found survey	Survey with a minimum of interpretative input.
Base line	A line between 2 points of known position: used as a reference for orientation.
EDM	Electromagnetic Distance Measurement : can be by use of reflector or Reflectorless [REDM].
End-over-end	The extension of a base line by orientation to its start point.
Laser	<b>L</b> ight <b>A</b> mplification by <b>S</b> timulated <b>E</b> mission of <b>R</b> adiation - the infra-red beam used by REDM for distance measurement <i>and</i> target pointing is laser modulated. Laser light will travel in a narrow beam but it is subject to reflectance and beam divergence.
Orientation	The primary direction from which measurement is made. Orientation is an essential process in any survey. Orientation requires a start point [origin] and a direction.
Photogrammetry	The science of extracting measurement and drawings from [stereo] photography. Classical photogrammetry requires the use of a calibrated camera and a stereo plotter to produce 3D wire-frame data or orthophotographs.
Rectified photography	A photograph where the tilt and scale of the image have been adjusted to fit control values; typically mono-planar.
Resection	The solution of an unknown location by EDM observations to at least 2 known points to determine the point of occupation.
Tribrach	An interchangeable base plate for theodolite and targets: levelled by 3 foot-screws and centered over a point with an optical or laser plummet.
Traverse	A network [usually a loop] of points derived from rigorous adjusted measurement of angles and distances.

Lunnon, S (ed) 2003 *Measured & Drawn: Techniques and Practice for the Metric Survey of Historic Buildings*, Swindon: English Heritage  
ISBN: 1 873592 72 8

Allan, A L, Hollwey, J R and Maynes, J H B 1968 *Practical Field Surveying & Computations*, London: Heinemann  
ISBN: 0890967849

EH 2000 *Metric Survey Specification for English Heritage*, Swindon: English Heritage  
ISBN: 1 873 592 574

Rainsford, H F 1968 *Survey Adjustment & Least Squares*, Constable  
ISBN: 09 455 270 3

EH 2000 *Presentation of Historic Building Survey in CAD*, Swindon: English Heritage

Wilson, R J P 1978 *Land Surveying*, Macdonald and Evans Handbooks  
ISBN: 0 7121 1242 1

Uren, J and Price, W F 2005 *Surveying for Engineers*, 4 edn. Palgrave Macmillan  
ISBN: 1403920540

Leica Geosystems. 2002. TCR 300 series User Manual: product code 710597-1.0en  
2002

Anderson, J M and Mikhail, E M 1998 *Surveying: Theory & Practice*, 7 edn. McGraw-Hill  
ISBN: 0 07 0159149

US Army Field Manual 3-34.331. 2001. *Topographic Surveying: Chapter 6*. [Online]. Published 16 January 2001  
Available from: <http://cartome.org/FM3-34/Chapter6.htm>  
[cited 9<sup>th</sup> January 2007]

Allan, A L 2003 *Maths for Map Makers*, 2 edn. Whittles Publishing  
ISBN: 1 870 325 99 0

# 4

**PART 4    RECTIFIED  
PHOTOGRAPHY**

# RECTIFIED PHOTOGRAPHY FOR HERITAGE DOCUMENTATION

## TECHNIQUE SUMMARY:

### TECHNIQUE

- Single scaled image
- Multiple image mosaic
- Digital Rectification
- Multi-planar rectification
- Control measurements 3D
- Control measurements 2D
- Archiving photography
- Metadata, annotation
- Camera performance
- Using low cost cameras
- CAD and GIS applications

OBJECT SIZE

<1m<sup>3</sup> to 30m<sup>3</sup>

PRECISION

+/- 10-30mm

SOFTWARE

Photoshop 2D CAD Digital rectification package

### SKILLS REQUIRED

Photography, aligning the camera, setting out control.

Anticipating image cover and balancing exposures.

3D surveying for the definition of multiple planes.

Systematic observation and, anticipation of results. Use of EDM (3D) and proper use of level and plumb line (2D).

Indexing, archiving and managing metadata.

Be able to encode and understand the need for recording camera data, data backup and data provenance.

Understand and communicate the limits of the equipment used.

CAD literate, 3D aware, understand vectorisation, layering and line weights/scale  
Digitising, photo-mosaicing and layering image data in CAD and GIS.

### APPLICATION

#### 1. SCALEABLE SITE RECORD

Rapid capture of site information with minimum equipment.

#### 2. RECTIFIED PHOTO-MOSAICS

CAD ready photo-mosaics as condition records of elevations, floors, etc.

#### 3. BASELINE RECORDS OF CONDITION

Material condition and texture can be recorded using rectified photographs.

#### 4. ON SITE VERIFICATION OF METRIC SURVEY

Support for interpretative drawings, diagnostic detailing, component diagrams and explanatory sketches.

#### 5. INFILL TO OTHER METRIC TECHNIQUES

Composite vector and image products are very successful in meeting a variety of project needs: floors wall and ceilings where the subject is reasonably flat can be recorded economically. If colour is important (wall paintings mosaic decoration, etc), good quality scalable imagery works well.

#### 6. LOW COST METRIC SITE RECORDS

Where resources are limited a 2D scaleable photographic record can be achieved with rectified photography.

### ASSOCIATED TOOLS/ SKILLS

Darkroom / Digital image processing

Controlling the scale and quality of prints produced by a third party dark room can be difficult. Digital processing requires care to get adjustments consistent across batches, and care in achieving properly resourced archiving and copy production.

Photography using consistent lighting with balanced exposures to both record detail and texture is essential. Understanding how to achieve photo-coverage of the full extent of the subject is vital: experience in framing and camera position is a must.

## CONSTRAINTS ON APPLICATION

Rectified photography is a relatively simple technique that can be extremely useful in preparing records of subjects like decorated floors or wall-faces with textural detail. Using rectified photography to record relatively flat objects is very effective, BUT if the subject has a complex 3D surface the method will fail because it is a 2D technique.

## KEY CONCEPT: THE PLANE OF RECTIFICATION

The required metric control used for rectified photography is a minimum of 3 points (ideally 4) fixed by measurement: these points will define the plane upon which the image is corrected. If we consider the façades of a building as planes it can be seen that each façade could have its own plane of rectification.

Fig 4.1 RECTIFIED PHOTOGRAPH OF A BYZANTINE MOSAIC FLOOR. Below: the camera position for the original captured image was severely restricted by the fragile nature of the floor. Right: the rectification using a simple measured square. Note that the considerable distortion of the perspective image is removed but that the image quality is compromised in the top third. The plane of rectification, in this case, is the plane of the floor.



## PROPERTIES OF THE IMAGE

The quality of the corrected image is largely dependent on the quality of the camera used and the exposure taken. Care must be exercised to avoid the use of images with extreme tilts, lenses with extreme distortions, (i.e. wide-angle, fish-eye) and exposures using poor lighting, inadequate camera support or badly matched media sensitivity.

## DIGITAL CAPTURE

A digital image is extremely useful as digital rectification techniques are quick, relatively cheap and can be used for overlay work in CAD or GIS systems. Cameras with large pixel arrays are generally better than smaller ones as more information is captured. Good quality images (e.g. 6 mega-pixel or better) generate large file sizes, so provision should be made to store and handle them.

## CONSIDERATIONS IN USING RECTIFIED PHOTOGRAPHY

Rectified photography is a relatively quick and simple survey method useful in circumstances where the subject is flat and contains a large amount of textural detail. The technique must be used with caution, however. A standard photograph of, for example, a wall cannot usually be used to scale off accurate dimensions because of errors caused by one or more of the following:

- the camera lens is not completely distortion free. This is usually the case with 35mm film cameras and consumer digital cameras, especially those with wide-angle lenses.

- the façade of the wall is not completely flat, so parts of the wall nearer the camera appear to be larger than those further away.
- the photograph was not taken with the negative plane of the camera completely parallel to the façade of the wall, so the scale varies across the image.

To rectify means to correct, adjust or redress an error. In the term 'rectified photography', the correction applies to errors in the scale and position of objects in a photograph.

## ERROR REDUCTION

Although we use the term 'rectified photography', the usual aim is to minimise error while taking the photograph and to make only minor adjustments by rectification. Improved image resolution is achieved by using a high quality large-format (5in. x 4in.) camera. Taking care to ensure that the camera is parallel to the façade will lessen the risk of varying scale. A mono-rail camera is ideal because the rising front and other movements can be used to avoid tilting the camera. If a wall is made up of a number of distinct planes it is possible either to scale the same photograph several times or to take separate photographs for each plane. Where a wall is undulating or has many planes, rectified photography may not be suitable.

## SCALE AND CONTROL

To have metric performance the photograph must be scaled. This can take the form of a simple scale bar or measured targets fixed to the façade. The distances between the targets can be determined with a tape measure or by EDM.



Fig 4.2 SIMPLE SCALED IMAGE

By including a scale in the image some metric information on the plane of the scale can be recovered.



Fig 4.3 LARGE FORMAT (5in x 4in) MONO-RAIL CAMERA

This camera has almost unlimited movements of the image plane relative to the lens plane. This is extremely useful in removing tilts in the image at capture. Digital capture is now possible with these cameras by use of a digital back: the large format means very high resolution images are possible.

Photographic negatives can be printed to scale using darkroom methods. Improvements in the quality of digital cameras mean that images can now be used for rectification on a PC. Film captured images can be used with digital tools if scanned from negatives. Where darkroom methods are employed, the enlarger head will be raised or lowered until the required scale is achieved by matching the image against a scale rule or a plot of the targets. Tilting the copyboard can compensate for minor displacements in the image plane. Rectification requires a minimum of three but usually four measured targets per image, although correction can be achieved using identification of horizontal and vertical lines. Once the image has been rectified it can either be printed at the required scale or combined with vector data to produce a composite product. With most digital rectification packages it is possible to produce a mosaic from a number of photographs. This facility is useful for subjects such as tiled floors, where it is impossible to cover the whole subject

with a single shot.

## LOW COST RECTIFIED PHOTOGRAPHY

It is possible for rectified photography to be carried out with relatively low cost equipment. Much useful work can be done using a standard 35mm format camera, although the larger the format/number of pixels and the better the quality of the camera, the better the results will be. It should also be remembered that wide-angle lenses suffer from greater lens distortion, particularly towards the edges of the format. A tripod, a hot shoe spirit bubble and a 1m long spirit level will also be required.

## IMAGE CAPTURE PROCEDURE

The camera is mounted on the tripod and levelled using the hot shoe bubble. There are four conditions to ensure the captured image is square-on to a façade and scalable:

1. Horizontal axis is truly level
2. Image plane is parallel to façade plane
3. Control is present in the image area
4. Camera back (image plane) is vertical

The image plane can be brought approximately parallel to the façade plane in two ways:

1. Sighting the centre line of the view finder onto a line set out normal to the façade (e.g. by 3,4,5, triangle).
2. Setting up a level line on the façade (e.g. by placing a long spirit level or a levelled chalk line) and aligning a horizontal line in the view finder to it. The camera is then rotated from side to side until the spirit level appears to be parallel with the base of the viewfinder. For this method to work the spirit level must appear close to the bottom or top of the format.

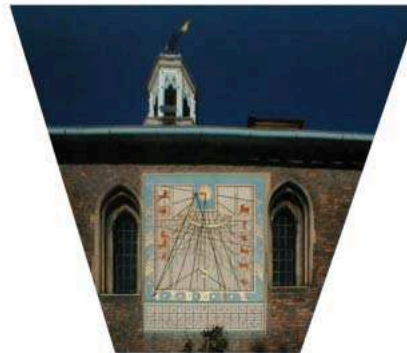
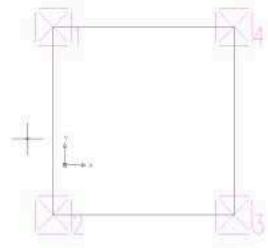
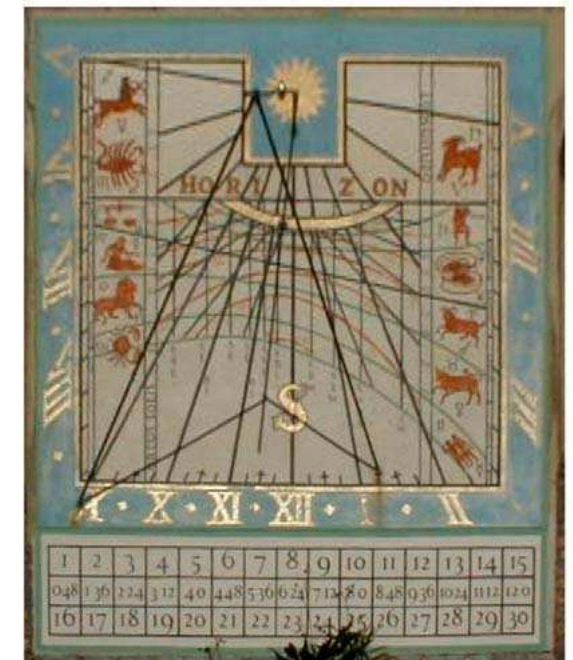

Fig 4.4 RECTIFIED PHOTOGRAPH OF A MURAL SUNDIAL

The camera-subject distance has caused severe perspective distortion which is removed by rectification (in this example using PhoToPlan®). Once rectified, the image can be used for scale drawing production provided only the plane of rectification is worked upon. This image was captured with a low-resolution camera and the effect of this can be seen in the top half of the rectified image. The slight curvature of the horizontal lines in the lower part of the image is due to barrel distortion; this is an effect of a wide-angle lens.





# RECTIFIED PHOTOGRAPHY : IMAGE CAPTURE

Where more than one photograph is required to cover a façade it will usually be necessary to use measured control targets for scaling rather than just a scale bar. This will help maintain overall accuracy as the distance from the first photograph to the last will be known.

Square-on photography can be scaled in CAD provided the image is truly parallel to and co-planar with the subject. It is always best to take imagery 'square-on' to any principal architectural features like doors, windows, niches etc. Although any oblique image can be rectified, you will always end up with a skewed image of a feature like a door, window etc if not taken square-on. A digitising tablet can be used to scale a tracing of the image provided it contains sufficient control to achieve this. The tablet will be calibrated using co-ordinate values for targets appearing in the photographs or a scale bar. As an alternative to a digitising tablet, a 'heads up' approach is possible using digital images inserted into a CAD drawing and scaled/rotated to fit detail or control points. Detail can then be traced on screen or the image can be used as part of the drawing in its own right.

Digital images can be prepared for digitising or mosaic production by using photo-editing software to compensate for distortions due to perspective, to balance colour and contrast, or to crop extraneous information after rectification.

To understand the scope and limitations of rectified photography, those with little or no previous experience will require field and office practice. The photographer preparing rectified images will also benefit from hands-on knowledge of CAD, good quality three-dimensional control and a methodical and systematic approach to undertaking survey.

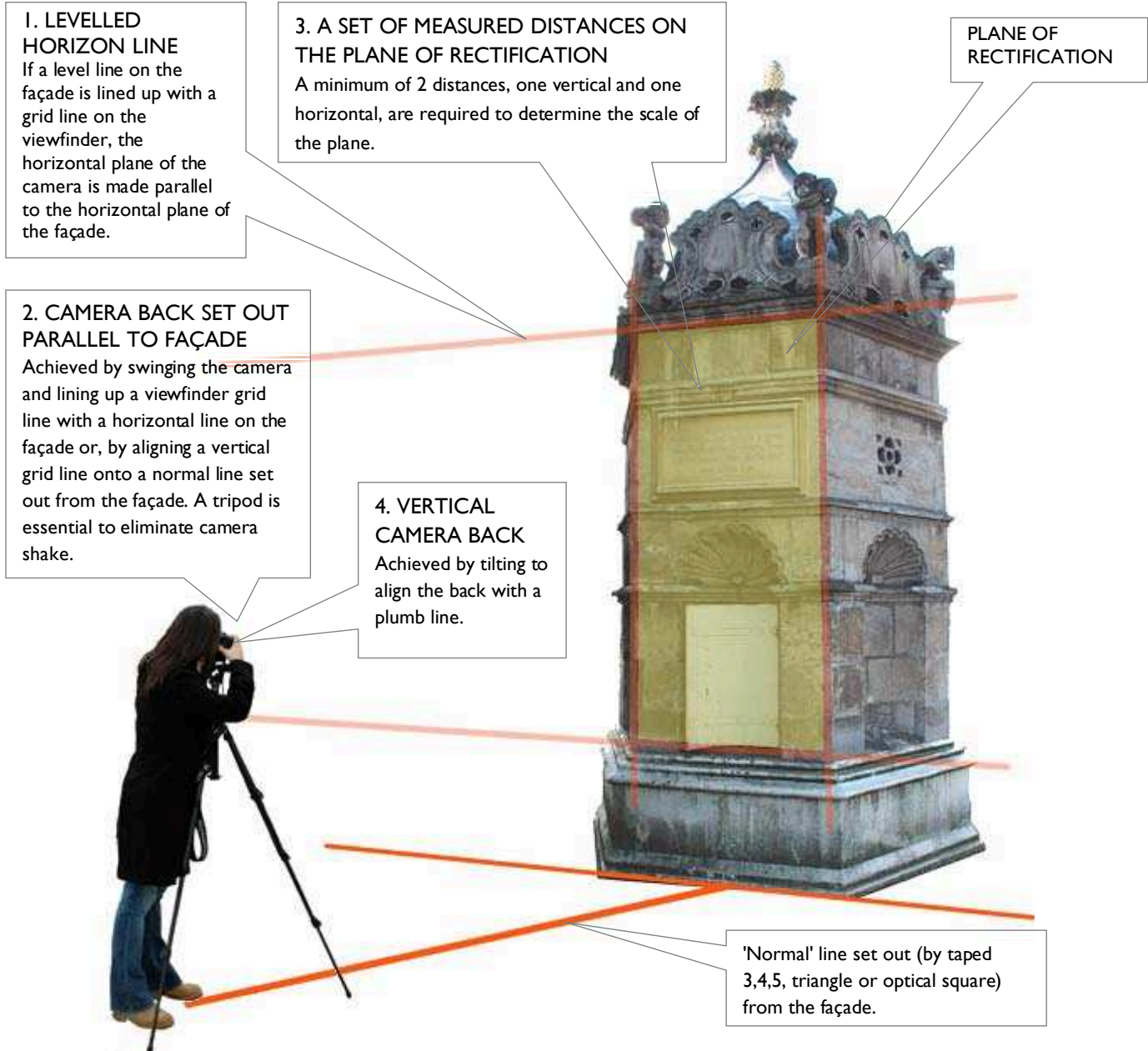

Fig 4.5 THE 4 REQUIRED CONDITIONS FOR A SCALED SQUARE-ON PHOTOGRAPH. The image plane is set up parallel to the façade plane (shown in yellow): the required geometry is indicated. In this case a vertical and horizontal line imposed on the façade with a measured distance determines the façade plane. Alternatively control points fixed by REDM can be used.

# RECTIFIED PHOTOGRAPHY : IMAGE RECTIFICATION

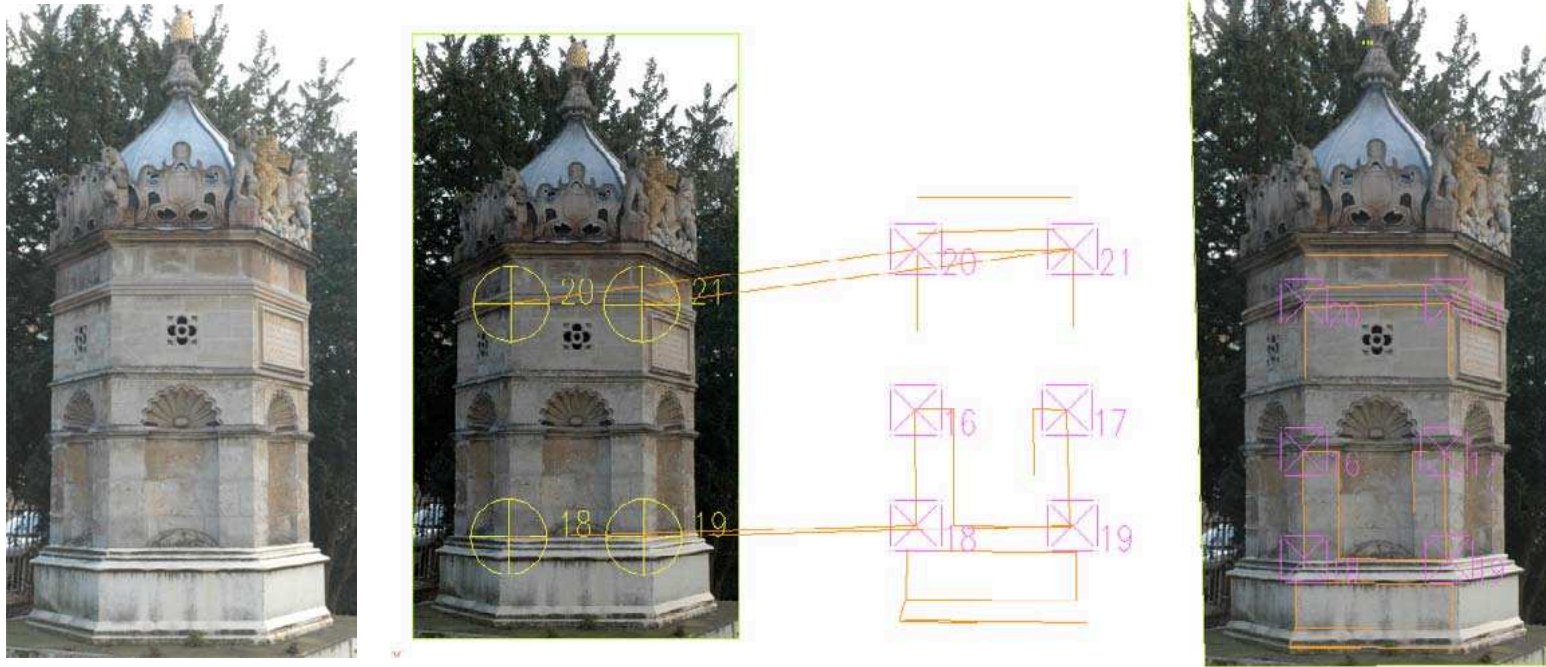
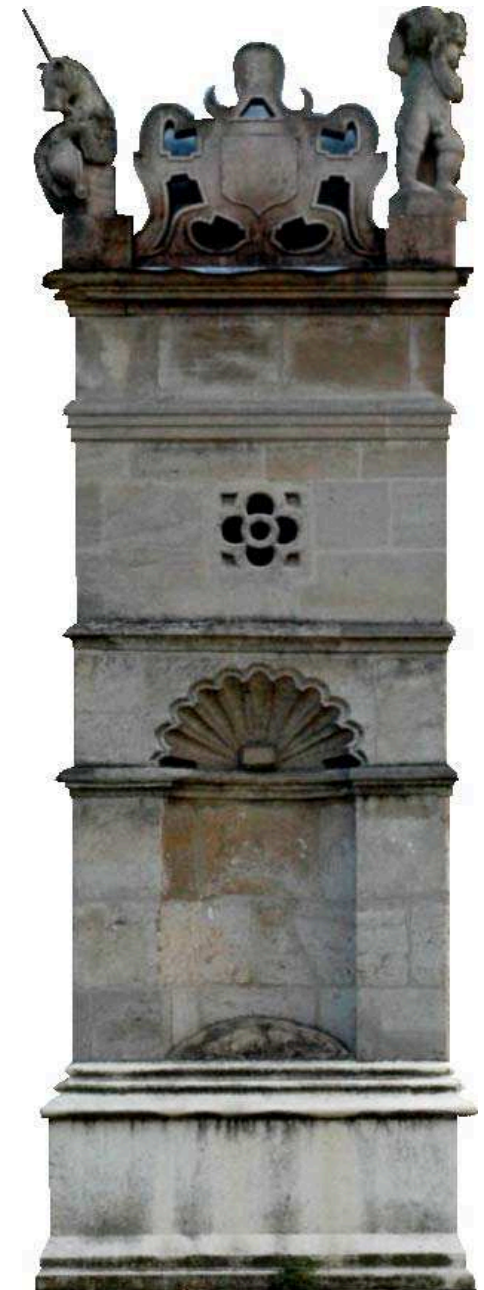
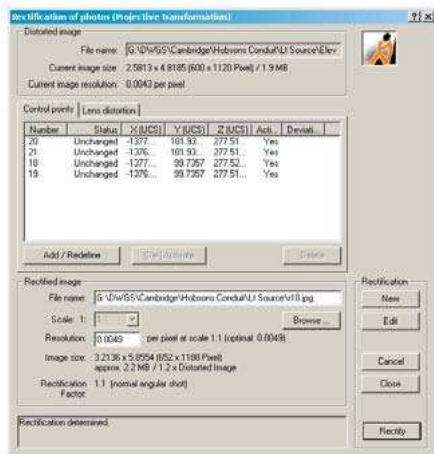

Fig 4.6

## DIGITAL IMAGE RECTIFICATION IN CAD

The distorted image (top left) is placed on the required plane (in AutoCAD®, the UCS). The control points are identified with a numbered symbol. The control points (measured as end points of lines in the 3D wire-frame in this example) are matched with their corresponding details. A report on the geometry is generated for review of the selected positions and the likely outcome of the rectification (lower left). The rectified image is generated, trimmed and plotted to scale (right). The trim line has been digitised onto the rectified image and then used to cut away the extraneous image area. This example is prepared using PhoToPlan (an extension to AutoCAD®) in conjunction with measured data from REDM. Note that only the rectified plane is presented, as all other planes will not be true to scale: it is possible to resolve this by re-rectifying the further planes in the façade and mosaicing the results for a multi-planar rectification. Rectifications in CAD are quick as the match between the measured wire-frame and the photograph can be checked easily. Alternative methods can handle bigger image file arrays and carry out sophisticated colour and exposure matching. Camera calibration data can be used to standardise the correction of lens aberration and distortion in most image rectification packages.



## RECTIFIED PHOTO-MOSAIC

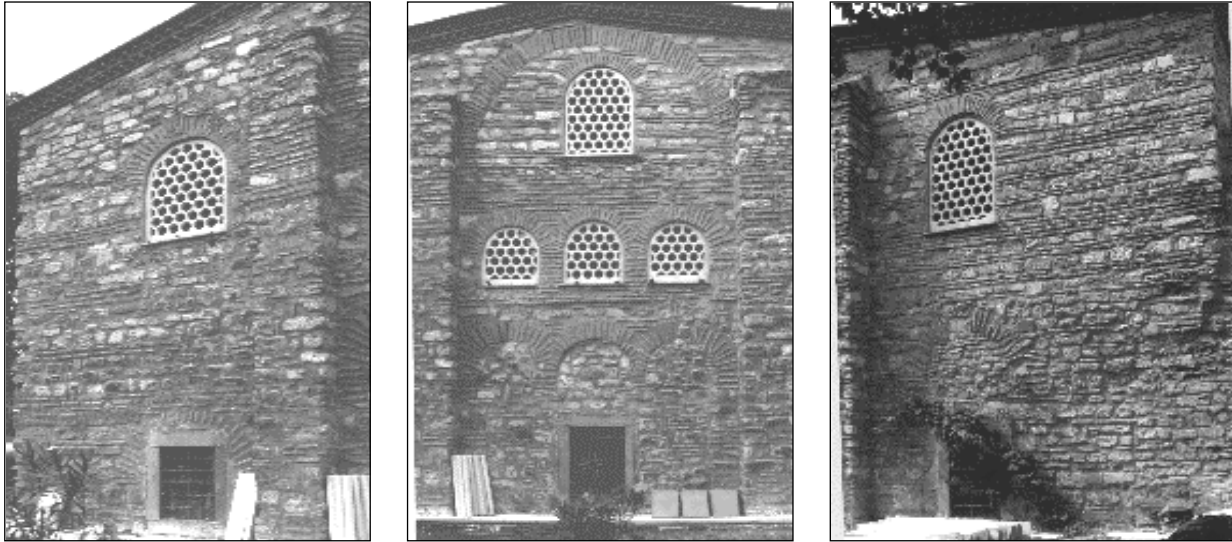

Fig 4.7

ATTIK MUSTAFA PASA CHAMII, ISTANBUL, TURKEY

Documentation project by: ETHZ (Eidgenössische Technische Hochschule Zürich): André Streilein, 1995

In this example a large format camera was used to capture the 3 images. Control was provided by measurement to detail points using REDM. The rectification was undertaken digitally. Note the problems caused by clipping the image area at capture (top left). When the image is rectified, the perspective correction will cause the aspect of the image to change. This can be avoided by use of either infill imagery or careful framing of 'square-on' images. In the mosaic it is possible to identify the joins between the images; this can be ameliorated by various feathering techniques such as channel filtering or layering in a photo-editing package. Photo-mosaics can be very effective for recording objects that cannot be captured in a single image. This can occur when the camera-subject distance is compromised or when the tilt from a single camera position is unacceptable. By separating out areas of an image onto different planes and re-rectifying them, mosaics can show a final image comprising multiple planes of rectification. For example, in the mosaic shown the buttresses can be separated and re-scaled using a different plane to the principal façade. Photo-mosaics require carefully balanced exposures so that the tonal values across the combined image are consistent. Much correction work can be done but there is no substitute for getting the exposure right at capture. Colour balancing can be problematic and using a colour index card for reference exposures can help to ameliorate this. Shadow can be both revealing and damaging to the record: taking of survey imagery in strong, raking sunlight will cause intense shadows across the mosaic and minimise data derivation. Ideal conditions are on reasonably high level overcast days. In the case of petroglyphs and pictographs, raking light may be used to highlight the surface features. The photographer must be aware that strong light is not always best for clear definition of details across a façade.

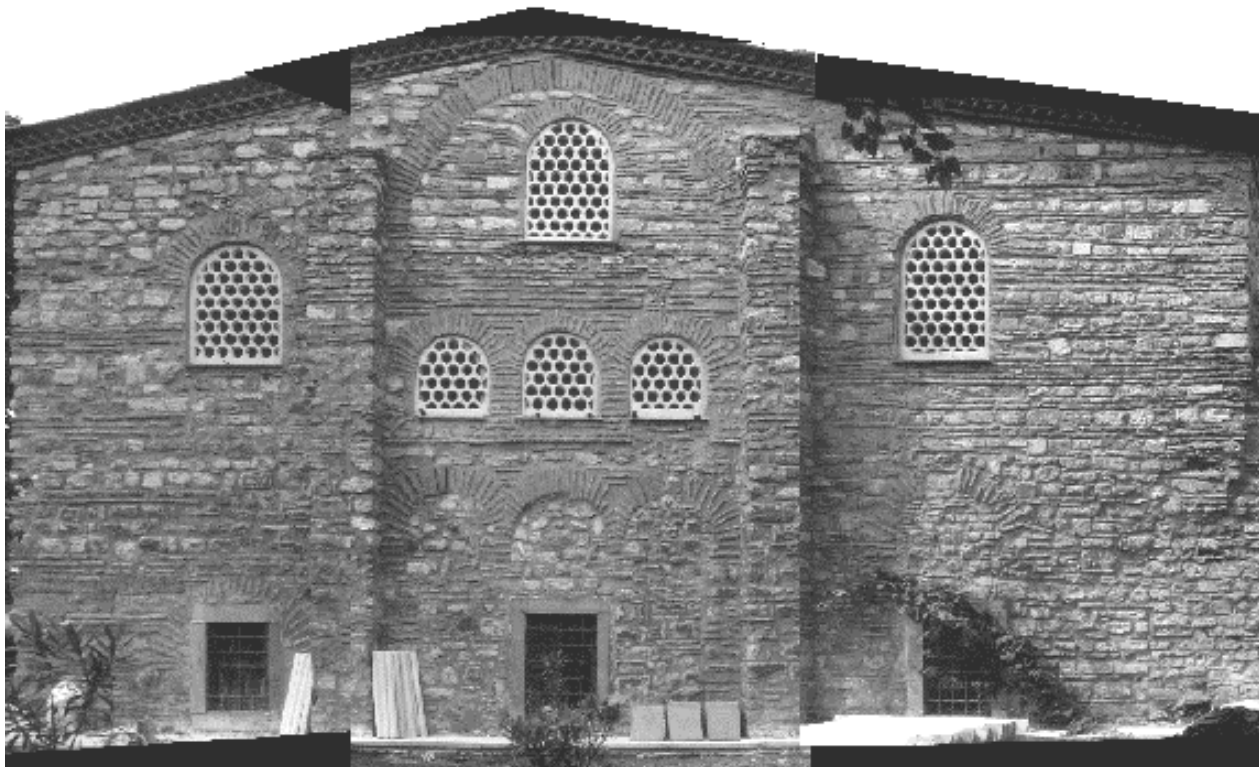



Fig 4.8

## DIGITAL RECTIFIED PHOTOGRAPHIC SURVEY USING LIMITED STAND-OFF

This photo-mosaic (right) made use of the performance of digital rectification. The photographs of the upper level of the gable wall are tilted due to the lack of stand-off (only 3m) possible on the site: the control points have been positioned with the help of a ladder and measured by reflectorless EDM in anticipation of the photo-cover possible. The camera used was a Kodak DCS pro using a wide-angle (28mm) lens set to focus on infinity. The enlarged detail (centre) shows an example of the fixed target used to mark a control point.



## PHOTO-MOSAIC OF A MEDIEVAL TILED FLOOR

The photographs for this survey were taken from a tripod mount using an offset bar. The camera-subject distance achieved (by using a ladder to look through the viewfinder) was 1.8m. The camera was a Kodak DCS Pro. Coverage of the entire floor was achieved in 27 exposures. The component imagery (examples left and detail below) included reference colour indexing cards.

## CONTROL

Control was established by reflectorless EDM observations to miniature target markers temporarily fixed to the surface of the floor.

## MOSAIC

Balancing the contrast, colour and edge overlap (the variation can be seen in the component images, left) is a skilful process: preparatory work in an image editing package to achieve common colour balance and contrast across the batch of imagery is essential.

## IMAGE FILE SIZES AND IMAGE RESOLUTION

Good resolution in the mosaic is dependent on good resolution in the component imagery. It is sometimes necessary to reduce the image file size to improve 'handling'. This should be done with care and tested on sample areas before reduction to maintain the required resolution in the assembled mosaic.



Fig 4.9

Left: the colour index card and a control point marker. The mark is a small adhesive circle with the 'butterfly' design.

Right: the photo-mosaic forms an optimum record of both the condition and the design of the floor. This segment is approx. 4m x 5m in extent.





#### CONDITION MONITORING FROM A PHOTO-MOSAIC.

This photo-mosaic was prepared from high resolution digital photography (14Mpixel capture in this case): it is therefore possible to resolve detail in the mosaic at a scale of 1:20.

An assessment of the condition of the fabric can be made by examination of the image to reveal:

1. Surface texture is apparent so that impact damage striation can be seen.
2. The degrading of the matrix can be seen as open joints between the tiles.
3. Colour weathering can be seen as losses in the lighter coloured glazes.
4. Losses of individual tiles are recorded.
5. If the photography is adequately controlled, archived and repeated over a monitoring cycle, an assessment can be made of the rate of condition change.

## USING THE COLOUR CARD

This card was devised by the International Federation of Rock Art Organisations to help the recording of colour in rock art photography. It is designed for close-up photography (up to 4.5m stand-off). The colour card can be used to help standardise the printing of colours across a range of images.

## PRINTING THE CARD

To achieve true colour reproduction with a typical office printer is almost impossible, but some precautions can be made to achieve a local calibration standard:

1. Use the ICC colour profile for your printer.
2. Use the highest quality medium to print onto.
3. Keep a record of the printer, its service record, colour profile, medium and environment.
4. Store the card away from strong light, in a dry and cool environment. Use it as soon after printing as possible.

The card on this page should be printed at full size (uncheck the resizing settings in Acrobat), on photo quality card; it is advisable to check the scale of the print, as some printers will auto-scale according to the paper size.

Note the RGB values on the card and check they have been transferred correctly: your local viewing settings may automatically adjust them.

## PHOTOGRAPHING THE CARD

Include the card in all shots, although you may wish to take duplicate shots without the card for mosaicing and keep the indexed shots for reference. Take care to avoid flare from the surface of the card by placing it away from the direct light generated by the flash gun.

## PRINTING THE IMAGES

If a colour match is critical, the same card that was photographed can be supplied to a professional printer who will be able to use it for a local colour calibration.

## OTHER COLOUR STANDARD CARDS

Professional cards are available; they are costly but precise. Examples include the Gretag-Macbeth® card shown in Fig 4.9 and the Kodak® greyscale card.

For further information on the IFRAO colour card, go to <http://www.cesmap.it/ifrao/scale.html>

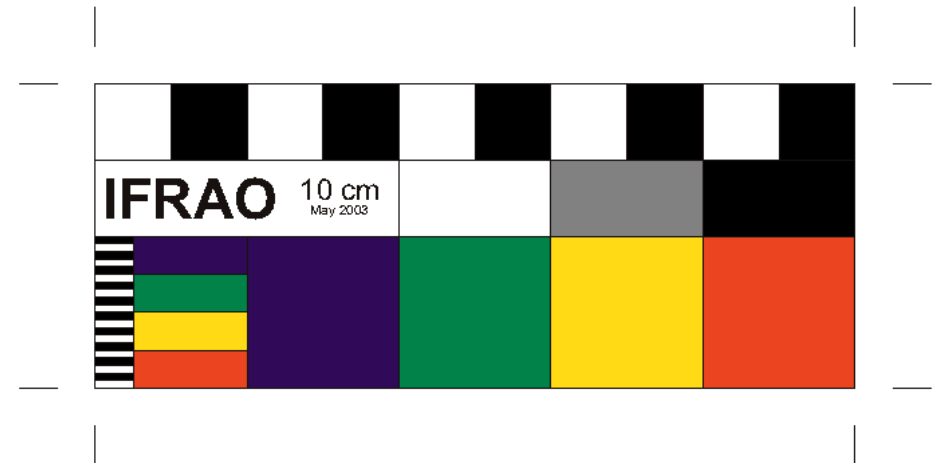

### RGB Codes:

Red: 214,0,39  
 Yellow: 255,215,0  
 Green: 0,134,73  
 Blue: 50,0,90  
 Grey: 128,128,128  
 Black: 0,0,0

IFRAO. All rights reserved  
<http://www.cesmap.it/ifrao/ifrao.html>

# GLOSSARY OF TERMS FOR RECTIFIED PHOTOGRAPHY

Barrel distortion	Barrel shaped curvature of straight lines in the image caused by lens optics: wide-angle lenses are prone to this (see Fig 4.4).
Camera calibration	A set of values describing the lens distortion and camera geometry measured from a test field (a simple case is a photograph of a precise grid) so that the rectification geometry can adjust for camera anomalies.
CCD	Charge Coupled Device: the light sensor in a digital camera
Colour balance	The correspondence (or otherwise) of colours or tones across an image or images.
Colour index card	A precise standard colour chart that can be used as an aid in balancing colour. The card is included in the image as a method of matching colours to a standard. Commonly used cards are: Gretag-Macbeth®, Kodak® and the IFRAO card which has been developed as a standard for rock art colour referencing.
Control point	A measured position used to scale and rotate an image: for rectification the control point must lie on the plane of rectification.
Façade plane	Principle plane of an elevation: few elevations have a single plane so a 'best fit' approach is used in rectified photography.
Gridded viewfinder	A viewfinder marked with a grid: the focussing screen on many cameras can be adapted to take a gridded screen, while digital SLRs use a synthetic one. Very useful for aligning the image plane to reproduce the vertical and horizontal axes of the object. Some consumer level cameras – such as the Canon PowerShot® A640 and Nikon® D70 also introduce synthetic grids.
Hot shoe bubble	The hot shoe is a 'u-shaped' fitting on the top of the camera that allows an external flash unit to be attached. A spirit level can be fitted to the hot shoe to ensure that the camera is level. A two-bubble variety is available for levelling both axes of the film plane.
Image area	The coverage of the subject area in a single photograph: it is important to know just how much cover is possible when placing targets for control points or planning overlapping cover for photo-montage work.
Image plane	The plane of the camera back.
Mono-rail camera	Camera designed to allow the independent movement of the lens plane and the image plane (Fig 4.3).
Normal line	A line at right angles to another.
Perspective projection	The projection of objects in a photograph is a perspective projection: This is the appearance of distant objects being smaller than those close to the observer: The perspective projection of objects in an image means they cannot be reliably measured.
Photo-mosaic	The process (and result) of making a composite picture by cutting and joining a number of photographs. The term 'photo-montage' is also sometimes used for the same thing.
Plane of rectification	The plane upon which the image is to be projected: it is usually co-incident with the façade plane for elevations.
SLR Camera	Single Lens Reflex Camera: the camera is designed to guarantee the viewfinder shows the image area exactly: the viewfinder sees the image area through the same lens that will take the picture.
Stand-off	Camera-subject distance.
Swing back	Property of mono-rail cameras in particular: the image plane can be tilted horizontally to distort the perspective view.

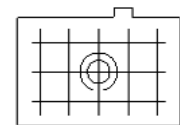
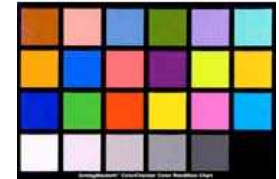



## FURTHER READING ON RECTIFIED PHOTOGRAPHY

Andrews, D, Blake, B, Clowes, M and Wilson, K 1995  
*The Survey and Recording of Historic Buildings and Monuments*  
Oxford: Association of Archaeological Illustrators and Surveyors  
ISBN: 0951672150

Ray, S F 1999  
*Scientific Photography and Applied Imaging*  
Focal Press  
ISBN: 0 240 51323 1

Andrews, D P, Beckett, N J, Clowes, M and Tovey, S M 2005  
A comparison of rectified photography and orthophotography as applied to  
historic floors – with particular reference to Croughton Roman Villa.  
*Proceedings of CIPA XX International Symposium, Torino, 26 September – 1*  
October 2005, Italy

Kubit GmbH. 2003.  
*PhoToPlan: Measuring with Photographs*  
[User Manual]  
[www.kubit.de](http://www.kubit.de)

Castleman, K R 1995  
*Digital Image Processing*  
London: Prentice Hall  
ISBN: 0132114674

Dorrell, P 1994  
*Photography in Archaeology and Conservation*, 2 edn  
Cambridge: Cambridge University Press  
ISBN: 0 521 45554 5

**Documentation for Conservation**  
A manual for teaching Metric Survey Skills

# 5

## PART 5 PHOTOGRAMMETRY

# PHOTOGRAMMETRY FOR HERITAGE DOCUMENTATION

TECHNIQUE SUMMARY:		SKILLS REQUIRED	APPLICATION
T E C H N I Q U E  S U M M A R Y	<ul style="list-style-type: none"> <li>Properties of Stereo Imagery</li> </ul>	Camera handling.	1. 3D STEREO RECORDS
	<ul style="list-style-type: none"> <li>Metric and non-metric cameras</li> </ul>	Awareness of calibration. Camera and tripod set up, flat, consistent exposure of overlapping pairs with appropriate camera-subject case and separation.	Stereo imagery is a basic requirement of the photogrammetric process. Image area control must be acquired to enable the extraction of metric data. Stereo pairs are a valuable record in themselves but much more so if control is recorded at capture.
	<ul style="list-style-type: none"> <li>Stereo capture</li> </ul>	Awareness of perspective depth.	2. ANTE DISASTER RECORDS Recovery of pre-disaster configuration of material from stereo imagery is a proven benefit of photogrammetry.
	<ul style="list-style-type: none"> <li>Photogrammetric techniques</li> </ul>	Stereo vision and good depth perception.	
	<ul style="list-style-type: none"> <li>Control measurements</li> </ul>	Measurement capability: use of EDM theodolite for precise façade control, requires traversing and computation skills.	3. STEREO MODELS Photo interpretation for reconnaissance can be achieved using a mirror stereoscope or mono-inspection.
	<ul style="list-style-type: none"> <li>Ante-disaster records</li> </ul>		
	<ul style="list-style-type: none"> <li>Performance of photogrammetry</li> </ul>	Interior and exterior orientation. Familiarity with theory of errors. Understanding feature extraction.	4. EXTRACT REQUIRED VECTOR DETAIL Photogrammetry can be used to produce line drawings. Skilled use of a photogrammetric workstation and software is required for setting up 3D models and digitising details.
	<ul style="list-style-type: none"> <li>Metadata, annotation</li> </ul>	Understanding object definition and selection. Scale and presentation conventions.	5. ORTHOPHOTOGRAPHS
	<ul style="list-style-type: none"> <li>Using photogrammetry for 3D CAD work</li> </ul>	CAD literate, 3D aware, understand vectorisation, layering and line weights/scale.	Accurate condition records of facades, floors, roof and landscapes: true to scale photo-maps.
	<ul style="list-style-type: none"> <li>The 3x3 rules</li> </ul>		
OBJECT SIZE	<1m <sup>3</sup> to 30m <sup>3</sup>	Be familiar with the relationship between plan and elevation, line weights etc.	
PRECISION	+/- 5-30mm		
SOFTWARE	Photogrammetric set up, 3D CAD		
ASSOCIATED TOOLS/ SKILLS	Calibrated Camera, EDM Theodolite Photogrammetric Workstation /software.  Photography, Surveying, CAD	Effective plotting of detail in a 3D environment requires skill and experience which can only be obtained through practise.  Be able to anticipate photographic outcomes to get the best exposure for recording details, textures and form: use knowledge of user needs to set up appropriate exposures and camera positions.	

## WHAT IS PHOTOGRAMMETRY?

Photogrammetry\* is the art and science of measuring from photographs. For measurements to be made, the precise geometry of the camera, stereo photo-cover (overlapping photography taken from two different viewpoints) and some form of control is required so that the measurements can be related to the real world.

Photogrammetry is immensely flexible and its performance for object mapping is only limited by the image quality, the geometry of the photographs relative to each other and the distribution and precision of the control measurements. Image capture is relatively rapid and cheap - when we send a mission to Mars (see below, Fig 5.1, images courtesy of NASA) it is a stereometric camera that records not only the scene but the size and distance of objects with the minimum expenditure of power.

Photogrammetry is a technique for measuring objects from images. The imagery may be film-based, but increasingly it is in digital form, stored on disc or tape. Digital images can be captured directly using a digital camera or scanned from negatives.

The results can be:

- co-ordinates of the required object points
- topographical and thematic maps
- architectural drawings
- ortho-rectified photographs
- textured /untextured surface or terrain models
- ante-disaster photo and control packages

One of the most important properties of photogrammetry is that it is an *indirect technique* i.e. objects can be measured without contact or selectivity. Traditionally, it is used for producing drawings, scaled images or obtaining measurements. The applications of photogrammetry are widespread and can be divided into two groups:

- Aerial photogrammetry
- Terrestrial Photogrammetry (also known as close range photogrammetry).

Aerial photogrammetry is mainly used to produce topographical or thematic maps and digital terrain models.

Among the users of close-range photogrammetry are architects and civil engineers (to produce as-built records of buildings or document their condition), archaeologists (to facilitate analysis of historic buildings), surgeons (plastic surgery), police departments (documentation of traffic accidents and crime scenes) to mention but a few.

The value of an image based record that can be exploited metrically must be recognised as a major asset in establishing baseline records of the condition of conservation, but this value must be balanced with the necessary skills in interpreting the image and extracting the required information.

\*Photogrammetry is a specific term used to describe the procedure of deriving measurements from photography (*photo* = light, *graphos* = drawing and *metros* = measurement). It should be distinguished from *photo-interpretation* or *photo-analysis* where the metric element is absent. Viewing stereo pairs for reconnaissance work is not considered as being photogrammetry unless conducted under proper metric constraints.



## BRIEF HISTORY OF PHOTOGRAMMETRY

1845: John Ruskin, the British architect and pioneer of the modern conservation movement, discovers Daguerreotypes of Venetian palaces and remarks "it is very nearly the same as carrying off the palace itself- every chip of stone is there- and of course there is no mistake about proportions".

1851: Only a decade after the invention of the Daguerreotype by Daguerre and Niepce, the French inventor Aime Laussedat develops the first photogrammetric devices and methods. He is seen as the initiator of photogrammetry.

1858: The German architect Albrecht Meydenbauer develops photogrammetric techniques for the documentation of buildings and founds the first photogrammetric institute in 1885 (Royal Prussian Photogrammetric Institute).

1866: The Viennese physicist Ernst Mach publishes the idea of using the stereoscope to estimate volumetric measurements.

1885: The ancient ruins of Persepolis were the first archaeological site recorded photogrammetrically.



1910: The ISP (International Society for Photogrammetry), now ISPRS, was founded by E. Dolezal in Austria.

Until 1945: development and improvement of measuring (=‘metric’) cameras and analogue plotters.

1964: VENICE CHARTER. Article 16 establishes the principle of documentation as a professional responsibility in conservation.

1968: First international Symposium for photogrammetric applications to historical monuments was held in Paris - Saint Mandé.

1970: Constitution of CIPA (Comité International de la Photogrammétrie Architecturale) as one of the international specialized committees of ICOMOS (International Council on Monuments and Sites) in cooperation with ISPRS. The two most active members were Maurice Carbonnell (France) and Hans Foramitti (Austria).

1970s: The analytical plotters, which were first used by U. Helava in 1957, revolutionise photogrammetry. They allow the application of complex methods: aero-triangulation, bundle-adjustment, the use of amateur cameras etc.

1980s: Improvements in computer hardware and software make digital photogrammetry accessible and practical.

Fig 5.2 Left: Abteikirche at Tholey from the north east.

Typical metric photo by Albrecht Meydenbauer, 1886.

Fig 5.3 Top right: Typical small format stereo-gram from 1898.

Fig 5.4 Bottom right: Typical ‘eye base’ stereo camera of the 1890s.

Stereo photography became a craze in the 1890s. Cameras and viewers were mass-produced and the novelty of stereo 3D only faded with the advent of cinematography: this is a good example of the strong human urge to explore virtual 3D environments; first using static stereo and then by viewing recorded motion.

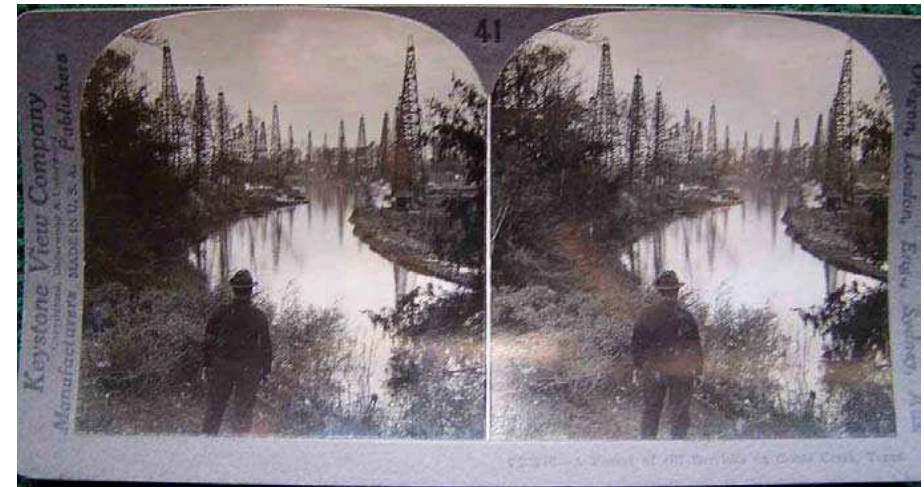

# ANTE-DISASTER RECORDS FROM PHOTOGRAMMETRY

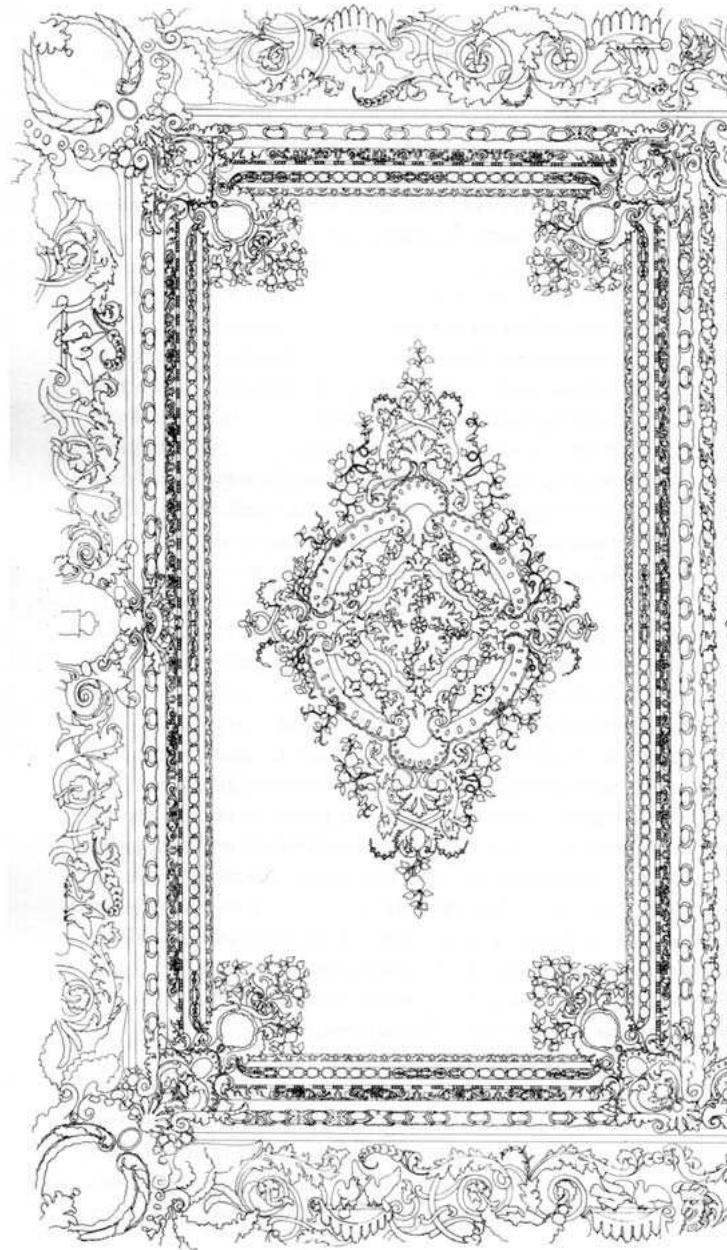

Fig 5.5

## VALUE OF A PHOTOGRAMMETRIC RECORD

Restoration of the Grand Reception room at Windsor Castle. Far left: fire damage to ceiling. Centre: 1:20 scale photogrammetric plot (reduced detail) from pre-fire field package captured in a working day using a Wild P31 camera and control points by observed EDM intersections. Below: restoration based on fragment recovery, re-assembly and new work based on the photogrammetric record. *Images used courtesy of the Royal Household and English Heritage.*



## PROPERTIES OF THE CAMERA

A photographic image is a perspective projection. This means that every ray of light which reaches the film surface (or CCD array) during exposure has passed through the optical centre of the camera lens (considered as a single point and known as the 'perspective centre'). In order to take measurements of objects from photographs, the ray bundle must be reconstructed. Therefore, the internal geometry of the camera has to be precisely known. It is defined by

- the focal length ( $f$ )
- the position of the principal point (PP) and
- the lens distortion.

The focal length, also known as 'the principal distance', is the distance between the perspective centre and the image plane at a point known as the principal point. For photogrammetric purposes cameras can be divided into two categories: 'metric' and 'non-metric'. A camera can be considered metric if the precise optical geometry is known.

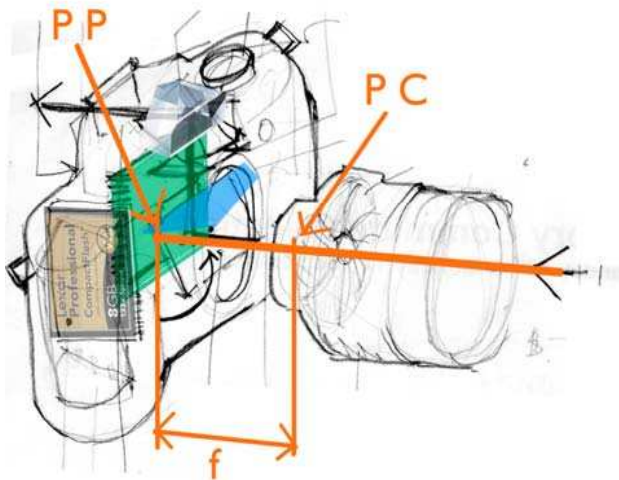

Fig 5.6 CAMERA GEOMETRY

The focal length ( $f$ ), perspective centre (PC) and principal point (PP). Lens distortion is also a part of the camera geometry, and is not shown in this diagram.

## METRIC CAMERAS

Metric cameras have stable and precisely known internal geometry and very low lens distortion. Consequently, they are expensive devices. The principal distance is constant, which means that the focus cannot be changed. As a result, metric cameras rely on depth of field to achieve a usable range of stand off distances. The image co-ordinate system is defined by a precise grid of at least four fiducial marks fixed on a calibrated plate (the Reseau plate), which is mounted on the frame of the camera. Terrestrial cameras (Figs. 5.7 and 5.8) are used with tripods while aerial metric cameras are built into aeroplanes.



Fig 5.7 METRIC CAMERA: WILD P31

Metric cameras are engineered to have lenses with extremely low distortion. The advent of high-resolution digital cameras (and the software to map distortions and adjust imagery) has made the manufacture of these cameras uneconomic. The performance of cameras like these is exceptional. Operators of this camera need to be able to use a light meter and handle a cassette film back, as well as be aware of survey procedure in setting up the tripod, tribrach and the required control.

## NON-METRIC CAMERAS

In photogrammetric terms a non-metric camera is a camera with unknown or un-calibrated internal geometry. Non-metric cameras, particularly high-end professional digital SLR models, can be very effective photographic devices. Non-metric cameras can be calibrated by photographing a test field with many control points and recording the distortion at a fixed focal length (for example at infinity). High-resolution non-metric digital cameras are becoming increasingly accessible and calibration routines are now widely available, so it is perfectly possible to use such images with digital photogrammetric workstations. Digital cameras do not require fiducials as the image co-ordinate system is defined by the four corners of the sensor. It is, however, extremely important that the focal length is fixed in some way and it is desirable to regularly check the calibration.



Fig 5.8 STEREO-METRIC CAMERA: WILD P32 PAIR

A stereo-metric camera is simply a fixed array of 2 metric cameras for simultaneous exposure of a stereo pair. This example uses a fixed base of 40cm. The cameras are set up and fixed parallel (or normal) to the subject to replicate the stereo performance of human vision.

## PHOTOGRAMMETRIC TECHNIQUES

Depending on the available equipment and the required results (2D or 3D, high or low accuracy), different photogrammetric techniques can be applied. Depending on the number of photographs, two main-categories can be distinguished, rectified photography and stereophotogrammetry.

### RECTIFIED PHOTOGRAPHY

Rectified photography is sometimes classed as a sub-set of photogrammetry. See Part 4 of this guide for details.

### STEREOPHOTOGRAMMETRY

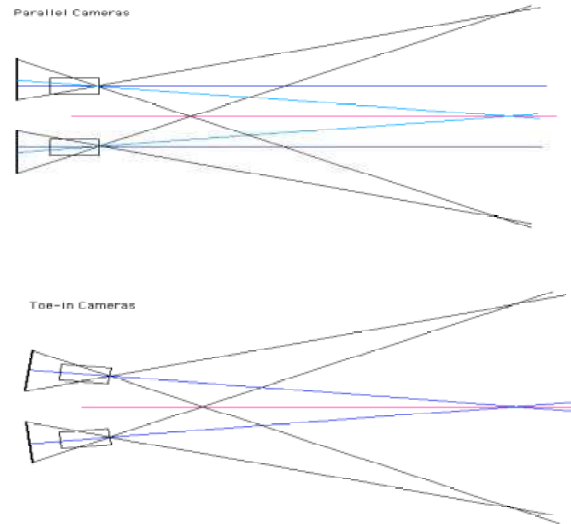

Fig 5.9 STEREO CAMERA CONDITIONS

To acquire stereo cover there must be an image captured from 2 positions of the same subject area. There are two cases used for classical photogrammetric work: Parallel (or Normal case) and Convergent (or 'Toe-in'). It is generally desirable to achieve a 60% overlap between images with a minimum of 4 control points in the overlap area.

As the term implies, stereo photographs are the basic requirement. These can be produced using one camera from two different positions or with a stereo-metric camera. The normal (or parallel) case is desirable. Vertical aerial photographs are usually close to the normal case. They are

taken with aircraft mounted metric cameras. While taking the photographs, the aeroplane flies over the survey area in strips or swaths, so that overlapping photographs cover the whole area. The overlapping parts of each pair of stereo photographs can be viewed in 3D and consequently mapped in 3D.



Fig 5.10 STEREOGRAM or STEREO PAIR

Separate and simultaneous viewing of the left and right images gives a 3D view. In this pair, the prints have been marked with the detail points used for control. The exposure has been made on a day with relatively 'flat' light so that shadow is reduced. The photograph is convergent and a vertical tilt has been introduced to get the required coverage.



## RESOLUTION OF IMAGE ORIENTATION

Before object geometry can be recovered from the stereo imagery it is necessary to replicate the image geometry as it was captured. There are three steps required to achieve this.

1. The interior orientation takes account of the geometry of the camera itself and establishes the image co-ordinate system.
2. The relative orientation recreates the camera positions and tilts relative to each other as the photographs were taken to produce a 3D stereo-model.
3. The absolute orientation relates the stereo-model to the real world co-ordinate system and introduces scale to the process.

There are three types of photogrammetric workstation: analogue, analytical and digital.

## ANALOGUE PLOTTERS

The analogue method was common until the 1970s but is now more or less replaced by analytical and digital techniques. Analogue plotters use an optical-mechanical mechanism to replicate the spatial conditions of the images at capture. Two projectors are set up to view the images with the same geometric properties as the camera (interior orientation). Their positions are exactly rotated into the same relationship to each other as at the moment of exposure by removing parallax (relative orientation). After this step, the projected bundles of light rays from both photographs intersect with each other forming the stereo model. Finally, the scale of the model has to be fixed and the rotations and shifts in relation to the mapping co-ordinate system are determined (absolute orientation). A minimum of three control points, which are not in a straight line, are required for this. The optical model is viewed by means of a stereoscope. The intersection of rays can then be measured using a floating mark. This consists of two marks, one in each view. When viewing the model, the two marks fuse into a single point, which can be moved in three

dimensions until it rests on the surface of the detail. The movements of the mark are mechanically transmitted to a drawing device like a pantograph as an operator traces round the detail.

## ANALYTICAL PLOTTERS

The first analytical plotters were introduced in 1957 but became widely available from the early 1980s. As with analogue instruments, transparencies are viewed in an optical-mechanical system, but it is computer controlled. The restitution of the stereo model is still carried out in three stages. As part of the interior orientation, however, the computer can now also correct for film distortion. The relative orientation is still achieved by removing parallax in the stereo view, but the photographs remain flat and the apparent tilts are applied by the computer, which continuously adjusts the positions of the photographs relative to each other. Absolute orientation is calculated by the computer once the control points have been digitised and their co-ordinates entered for processing. After the orientation, 3D detail can be extracted from the stereo-model. As with the analogue instrument, the model and a corresponding measuring mark are seen in 3D. An operator controls the movements of the mark, digitising by tracing round the detail, producing 3D data that is fed directly into a CAD system.

## DIGITAL PHOTOGRAMMETRIC WORKSTATIONS

Digital photogrammetric workstations (DPW) have become more widespread as computers became increasingly more powerful and economical in the 1990s. They comprise a computer with a 3D viewing screen and a 3D controller. Instead of transparencies, digital images are used. The images can be either direct from a digital camera or scans of conventional film negatives. The stereo models are set up in a similar way as for the analytical systems. The digital images are continuously re-sampled in order to maintain the correct 3D view. The relative and absolute orientations are often carried out concurrently and called the exterior orientation. The two

images are displayed, apparently simultaneously, on the screen and viewed by the operator using either a synchronised screen filter and fixed polarised glasses or synchronised polarising glasses so that the left eye only sees the left image and the right eye only sees the right image. Digital workstations can be used in the same way as analytical plotters to produce line drawings, but are also used to produce other products. The automatic matching of the stereo images means that it is quite easy to generate a digital terrain model (DTM) although some manual editing is usually required. The DTM can be used in its own right or can be used to produce an orthophotograph by adjusting the scale and position of each pixel in an image so that it is changed from a perspective projection to an orthographic projection. This means that any errors due to tilts of the camera or relief of the subject have been compensated for and therefore that it is possible to use the image like a map or a scaled drawing.



Fig 5.11 ANALYTICAL STEREO PLOTTING MACHINE

By viewing transparent diapositives of the captured stereo pairs this device can resolve the relative internal and external geometry of the stereo-pair, allowing 3D digitising to take place. The hand wheels control the position of the floating mark in the 'x' and 'y' axes and the foot wheel in 'z'.

## STEREO PHOTOGRAPHS

Stereo photographs are images that have been taken of the same subject from two different view points. The area of overlap between the images can be viewed in 3D. They are the foundation of any photogrammetric project but are also a valuable resource in themselves. The 3D view can be achieved using a simple stereoscope which forces the left eye to look at the left hand image and the right eye to look at the right hand image. This mimics human vision and therefore allows us to discern greater detail than we can in a standard photograph. In fact, stereo photographs often present a vertical exaggeration thereby making 3D features stand out. This is particularly useful, for example, when searching aerial photographs for archaeological features in the landscape.

## VALUE OF STEREO PAIRS

The stereo pair and its concomitant control data are the primary metric record in many cases. While it is impossible to anticipate the nature of a catastrophe, risk assessments can direct recording to the elements of a structure most at risk. Disaster preparedness planning includes the acquisition and archive of appropriate documentation, inventory and survey.

## FIELD PACKAGE

A set of stereo photographs, along with camera calibration information and suitable control, is an economic and powerful ante-disaster record. If a disaster does occur, the material can be retrieved from the archive and used to produce any of the products described below. The fieldwork element of a photogrammetric project typically represents only 20% of the final cost.

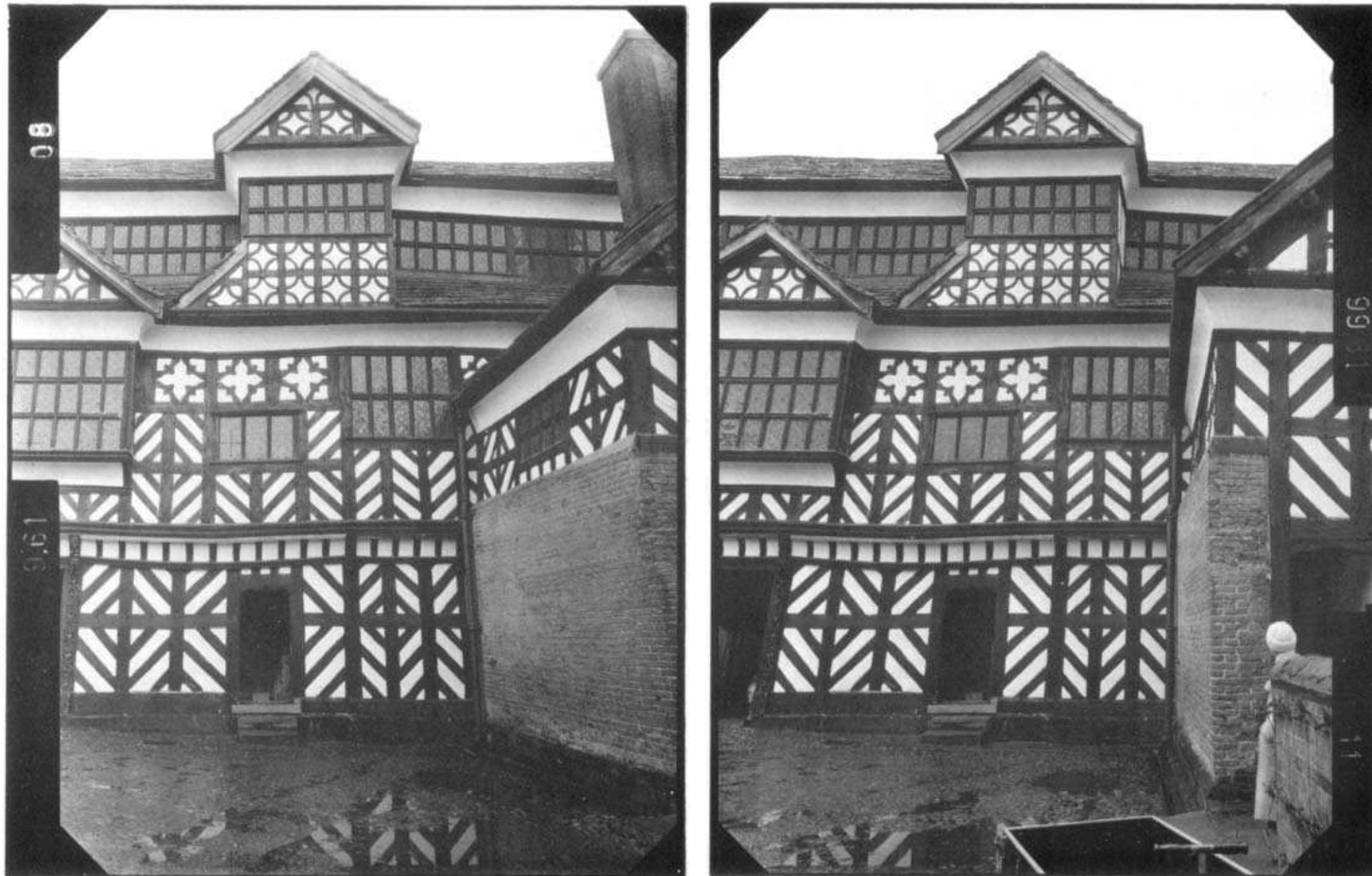

Fig 5.12 STERO-PAIR OF TIMBER FRAMED FAÇADE

The 'flat' lighting in this pair of images is deliberate: there is almost no sharp shadow in the scene. Choosing an overcast day for photography avoids problems of reflection from the glazing and helps the definition of the decorative framing by reducing glare from the white areas. Monochrome film stock is still widely used for film based work as the grain size is finer, a help when plotter operators work on magnified images.

## LINE DRAWINGS

The traditional photogrammetric product is a line drawing. These are produced by an operator carefully tracing round the required detail in 3D. The co-ordinates are streamed into a CAD system to produce the drawing. Although the data is three dimensional, the fact that the stereo photographs only allow one view limits the extent to which a true 3D model can be produced. As a result, the drawings are usually produced with only one view point in mind. This will be the view that is plotted out as hard copy from the CAD system.

## SCALE PLOT OF MASONRY FAÇADE

In Fig 5.23 the jointing of blocks can be clearly seen: this is information that can be prepared in advance of scaffolding for repair work. Note the depiction of jointing with a double line: this is a convention that can be specified in the commissioning of the photogrammetric survey according to project requirements. The small area behind the buttress (lower right) was not covered in the image area at capture and this is a typical occlusion: an infill technique (usually measured drawing) is needed to complete the plot.

## 3D MODELS

A surface can be generated by analysis of the stereo-model, a process which is automated in the digital workstation. The imagery can then be 'draped' over the surface, and additional imagery added to infill hidden areas as required. The surfaces of the model can be rendered with the photographic images.

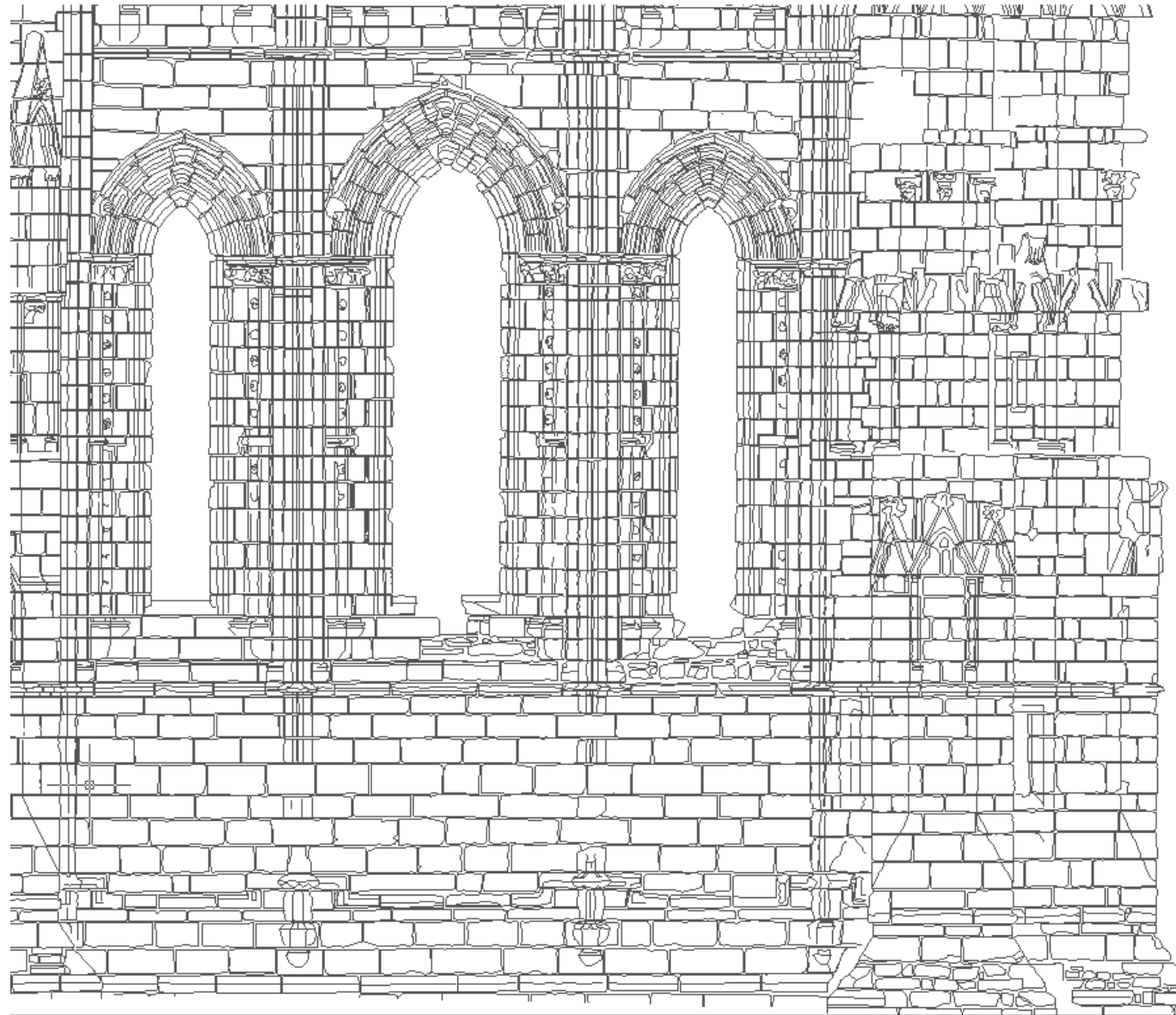

Fig 5.13 FAÇADE PLOT OF WHITBY ABBEY, NORTH YORKSHIRE

Stone by stone records can be achieved by photogrammetric recording; this example was prepared for 1:20 scale plotting. The edge definition in the plot is an indication of the condition of the stone work.

### DIGITAL TERRAIN MODELS (DTM/DEM)

A digital terrain model is a representation of the surface of a landscape, building or object (sometimes called Digital Elevation Model or DEM). It comprises a grid of points with x, y and z values. The grid can be regular or irregular. In the latter case the points are joined by lines to form triangles and the surface described is known as a triangulated irregular network (TIN). It is possible to produce a digital terrain model using an analytical plotter but this is very laborious as the operator has to place a point on the ground at every grid intersection. Digital Photogrammetric Workstations use automatic terrain matching algorithms to produce DTMs very quickly (Fig 5.14). The algorithms are not, however, infallible so a certain amount of manual editing is usually required. DTMs are useful in their own right for interpreting landscape, but are also the prerequisite for orthophotographs (below).

### ORTHOPHOTOGRAPHS

An orthophotograph is a photograph that has been corrected for any errors arising out of the relief of the subject or tilts of the camera relative to the façade, i.e. there is no variation in scale across the image. Orthophotographs are useful when an image-based product is required, especially when the relief of the subject is too variable for rectified photography to be applied. They are another product of digital photogrammetry, albeit a 2D output from a 3D system. A DTM/DEM is used to adjust the scale of an image pixel by pixel and thus convert a photograph with perspective projection to one with an orthographic projection – an orthophotograph. Once the orthophotograph has been produced it can be printed out at the required scale or imported into a CAD package. In CAD it can be combined with vector data from conventional photogrammetry to produce a composite product. It should be remembered that an orthophotograph is a two-dimensional product and so will contain no co-ordinate z values and

therefore no depth information. It is possible, however, to drape the orthophotographic image over the DTM using a 3D modelling or visualisation package.

Fig 5.14 DEM & ORTHOPHOTOGRAPH

Left: The DEM generated from the automatic surface generation phase of the digital photogrammetric process. The analysis of the stereo-model produces a 3D-contour model that can then be used for orthophoto-generation. The sharp edges defining the surfaces in this façade require considerable editing of the automatically generated surface. This is achieved by digitising break-lines in the stereo-model.

Right: Orthophoto of part of the façade of the Chenes Temple on the West Side of the Adivino Pyramid, located at the Maya archaeological site of Uxmal in the state of Yucatan, Mexico. In 1999, the pyramid was documented using close-range stereo photogrammetry. The success of the project led to the adoption of this technology by the Autonomous University of Yucatan (UADY) to support heritage preservation in Mexico and other Latin-American countries. Unlike a rectified photograph, the image is scalable across all planes.

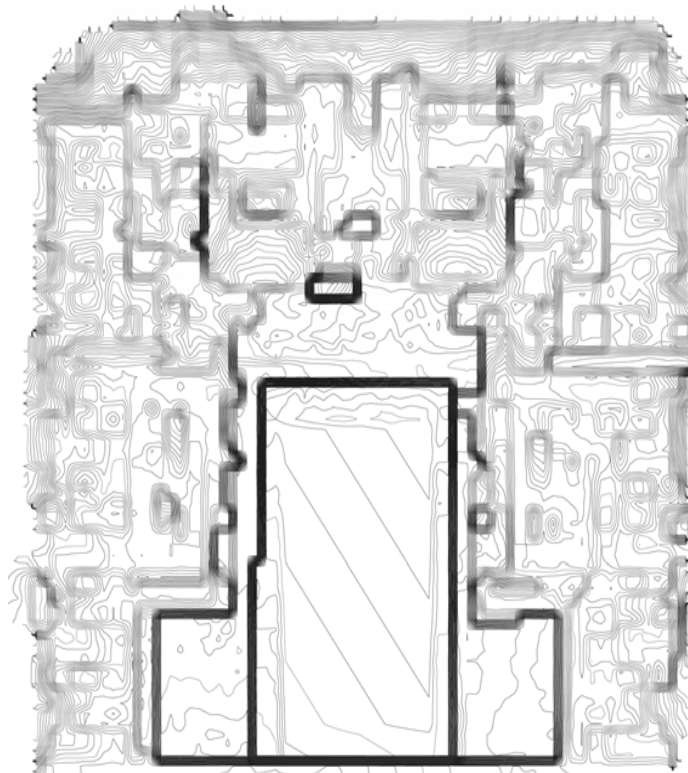

# PHOTOGRAMMETRIC CAPTURE : THE '3 x 3' RULES\*

1 - THE 3 GEOMETRIC RULES	2 - THE 3 CAMERA RULES	3 - THE 3 PROCEDURAL RULES
<p><b>1.1- CONTROL</b></p> <ul style="list-style-type: none"><li>Measure some long distances between well-defined points.</li><li>Ideally, establish a network of 3D co-ordinated targets or points.</li><li>Define a minimum of one vertical distance (either using plumb line or vertical features on the building) and one horizontal. Do this on all sides of the building for control.</li></ul> <p><b>1.2- STEREO PHOTOCOVERT : WIDE AREA</b></p> <ul style="list-style-type: none"><li>Take a 'ring' of pictures around the subject with an overlap of greater than 50%.</li><li>Take shots from a height about half way up the subject, if possible.</li><li>Include the context or setting: ground line, skyline.</li><li>At each corner of the subject take a photo covering the two adjacent sides.</li><li>Include the roof, if possible.</li><li>No image should lack overlap.</li><li>Add orthogonal, full façade shots for an overview and rectification.</li></ul> <p><b>1.3- STEREO PHOTOCOVERT : DETAIL</b></p> <p>Stereo-pairs should be taken:</p> <ul style="list-style-type: none"><li>Normal case (base-distance-ratio 1:4 to 1: 15), and/or</li><li>Convergent case (base-distance-ratio 1:10 to 1: 15).</li><li>Avoid the divergent case.</li><li>Add close-up square on stereo-pairs for detail and measure control distances for them or place a scale bar in the view.</li><li>Check photography overlaps.</li><li>If in doubt, add more shots and measured distances for any potentially obscured areas.</li><li>Make sure enough control (at least 4 points) is visible in the stereo image area.</li></ul>	<p><b>2.1 - CAMERA PROPERTIES</b></p> <ul style="list-style-type: none"><li>Fixed optics if possible. No zooming! Fully zoom-out, or fix the focus using adhesive tape or avoid zoom optics altogether. Do not use shift optics. Disable auto-focus.</li><li>Fixed focus distance. Fix at infinity, or a mean distance using adhesive tape, but only use one distance for the 'ring'-photography and one distance for close-ups.</li><li>The image format frame of the camera must be sharply visible on the images and have good contrast.</li><li>The true documents are the original negatives or digital 'RAW' equivalents. Use a camera with a highest quality format setting.</li></ul> <p><b>2.2 - CAMERA CALIBRATION</b></p> <p>Use the best quality, highest resolution and largest format camera available:</p> <ul style="list-style-type: none"><li>A wide-angle lens is better than narrow angle for all round photography. Very wide-angle lenses should be avoided.</li><li>Medium format is better than small format.</li><li>Calibrated (or metric) cameras are better than non-metric.</li><li>Capture medium: fine grain, high sensitivity film is better, and achieves higher resolution.</li><li>Standard calibration information is needed for each camera/lens combination and each focus setting used.</li><li>A standardised colour chart should be used.</li></ul> <p><b>2.3 - IMAGE EXPOSURE</b></p> <p>Consistent exposure and coverage is required.</p> <ul style="list-style-type: none"><li>Work with consistent illumination: beware deep dark shadows! Plan for the best time of day.</li><li>Use a tripod and cable release/remote control to get sharp images.</li><li>Use the right media: Black-and-white is sufficient but colour has some advantages for interpretation and documentation of colours.</li><li>Use RAW or 'high quality' and 'high sensitivity' setting on digital cameras.</li></ul>	<p><b>3.1 - RECORD THE SITE , CONTROL AND PHOTO LAYOUT</b></p> <p>Make proper witnessing diagrams of</p> <ul style="list-style-type: none"><li>The ground plan with the direction of north indicated.</li><li>The elevations of each façade (1:100 - 1: 500 scale). Show the location of the measured control points.</li><li>Photo locations and directions (with film and negative number).</li><li>Single photo coverage and stereo coverage.</li><li>Control point locations, distances and plumb-lines.</li></ul> <p><b>3.2 - LOG THE METADATA</b></p> <p>Include the following:</p> <ul style="list-style-type: none"><li>Site name, location and geo-reference, owner's name and address.</li><li>Date, weather and personnel. Client, commissioning body, artists, architects, permissions, obligations, etc.</li><li>Cameras, optics, focus and distance settings.</li><li>Calibration report, if available.</li><li>Description of place, site, history, bibliography etc.</li><li>Remember to document the process as you go.</li></ul> <p><b>3.3 - ARCHIVE</b></p> <p>Data must be complete, stable, safe and accessible:</p> <ul style="list-style-type: none"><li>Check completeness and correctness before leaving the site.</li><li>Save images to a reliable site off the camera. Save RAW formats to convert into standard TIFFs. Remember a CD is not forever!</li><li>Write down everything immediately.</li><li>The original negatives are archive documents. Treat and keep them carefully.</li><li>Don't cut into the format if cutting the original film. If using digital cameras, don't crop any of the images – use the full format.</li><li>Ensure the original and copies of the control data, site diagrams and images are kept together at separate sites.</li></ul>

\*The above text is adapted from a paper presented by Peter Waldhäusl (University of Technology, Vienna, Austria) and Cliff Ogleby (Dept. of Geomatics, University of Melbourne, Australia), at the ISPRS Commission V Symposium "Close Range Techniques and Machine Vision" in Melbourne, Australia, 1994. Simple rules that are to be observed for photography with non-metric cameras have been written, tested and published at the CIPA Symposium in Sofia in 1988.

# GLOSSARY OF TERMS FOR PHOTOGRAMMETRY

Camera calibration	A set of measurements made of the camera geometry and distortion for fixed focal settings.	The calibration data includes: <ul style="list-style-type: none"><li>▪ the precise focal length of the lens at exposure</li><li>▪ lens distortion, both in radial and tangential directions</li><li>▪ the central 'principal point' of the image sensor</li><li>▪ the exact dimensions of the individual pixels making up the sensor</li></ul>
Camera geometry	The constraints on the perspective projection of the configuration of the camera and lens.	
CCD	Charge Coupled Device: the light sensor in a digital camera.	
Control/photo-control	Measured points or lines used to resolve object geometry in the image area.	
Convergent case	Non parallel imagery or 'toed-in' camera positions.	
Diapositive	Positive image produced on a transparent support for viewing by transmitted light, i.e. transparency.	
Divergent case	Non-overlapping imagery.	
DPW	Digital Photogrammetric Workstation.	
DTM, DEM, DSM	Digital Terrain Model, Digital Elevation Model, Digital Surface Model.	
Fixed optics	Lens assembly with out adjustment for focus other than that fixed at a given distance or infinity.	
Focal length	The distance between the principal point and the perspective centre of the camera: it is a theoretical distance as (other than in a metric camera) the precise perspective centre is unknown in most cameras.	
Image area	The object area covered by the captured image.	
Image capture plane/Image plane	The theoretical plane upon which the images of the captured scene is projected in the camera.	
Metric camera	Camera with known internal geometry and lens distortion.	
Non-metric (amateur) camera	Camera with unknown internal geometry and lens distortion. Measurements can be made of the camera geometry and distortion for fixed focal settings for calibration.	
Normal case	Photos taken square-on and parallel to the subject.	
Object area	The space occupied by the subject to be recorded.	
Orthophotograph	An image in which all distortions are removed such that it has a true orthographic projection.	
Parallax	The relative displacement of an object in two images of the same scene taken from different positions.	
Perspective centre	The theoretical point through which the rays projected from the object intersect before they meet the image capture plane.	
Principal point	The precise centre point of the image and its corresponding point on the image capture plane.	
Shift lens/shift optics	Lens assembly with adjustment of the perspective centre position. Sometimes known as 'rising front' lenses.	
Software	Photogrammetric software falls into two groups: the stereo and mono. Stereo software is costly and will need a stereo viewing system, mono software is less costly but depends largely on various forms of perspective analysis to produce rectified images for both 2d and 3d work.	
Stereo model	The 3D image caused by fusion (in the brain of the viewer) of 2 separate but simultaneously viewed images.	
Stereo-pair	An image pair which has overlapping cover and an offset.	
Stereoscope/Mirror stereoscope	Method of viewing stereo pairs in 3D, usually non-metric.	
Zoom lens	A variable focal length lens. Zooming is a problem because the precise focal length must be known for photogrammetric purposes.	

## FURTHER READING ON PHOTOGRAMMETRY

Albertz, J 2001 Albrecht Meydenbauer – Pioneer of Photogrammetric Documentation of the Cultural Heritage. *Proceedings of CIPA 18<sup>th</sup> International Symposium*, Potsdam, 18-21 September 2001, Germany

Atkinson, K B (ed) 1996 *Close Range Photogrammetry and Machine vision*, Whittles Publishing  
ISBN: 1-870325-73-7

Bannister, A, Raymond, S and Baker, R 1998 *Surveying*, 7 edn. Longman  
ISBN: 0582302498

Belli, G 1995 *Il Rilievo Nei Beni Culturali*, BetaGamma  
ISBN: 88 86210 08 0

Chandler, J.H. and Fryer, 2005. Recording aboriginal rock art using cheap digital cameras and digital photogrammetry. *Proceedings of CIPA XX International Symposium*, Torino, 26 September - 1 October 2005, Italy

Linder, W 2006 *Digital Photogrammetry: A Practical Course*, Springer  
ISBN: 3540291520

Luhmann, T, Robson, S, Kyle, S and Harley, I 2006 *Close Range Photogrammetry: Principles, Techniques and Applications*, John Wiley & Sons Ltd  
ISBN: 0470106336

Mikhail, E M, Bethel, J S and McGlone, C 2001 *Introduction to Modern Photogrammetry*, New York: John Wiley & Sons Ltd  
ISBN: 0-471-30924-9

Stovel, H 1998 *Risk preparedness: a management manual for world cultural heritage*, Rome: ICCROM  
ISBN: 92 9077 152 6

Waldhäusl, P and Ogleby, C 1994 3-by-3- Rules for Simple Photogrammetric Documentation of Architecture. *Proceedings of the Symposium of Commission V of ISPRS*, Melbourne, 1-4 March 1994, XXX-5, Australia

# 6

G P S

PART 6



TECHNIQUE SUMMARY:

TECHNIQUE: GPS

TECHNIQUE SUMMARY:		SKILLS REQUIRED	APPLICATION
		Equipment operation and feature selection	Acquisition of points to map features on open sites.
	◆ GIS attribute geo-referencing	Inventory accessioning, closed polyline or node asset selection	GIS data capture for structured information sets. Point sampling site location for environmental monitoring.
	◆ Topographic surveying	Topographic data selection, detail identification, understanding heighting resolution	Detailed topographic plans/management plans/archaeological investigation.
	◆ Contour and DTM generation	Point capture density, heighting resolution, break-line mapping, surfacing and contouring software skills	Topographic surveys, 3D terrain models
	◆ Boundary & Perimeter mapping	Understanding the constraints on GPS performance, selection of perimeter, restitution to national mapping agency grid. Understanding local cadastral law	Buffer zone delineation, Monument inscription plans
	◆ Control points for site survey	Appropriate precision decisions. Understanding co-ordinates and the WGS84 system, using transformation to register GPS point on a map. Understanding heighting resolution.	Geo-referencing EDM traverses/ site-to-map fixes
	◆ Asset tagging	Database feature coding	GIS for heritage assets: point sampling sites for condition monitoring in landscape conservation
	◆ Multi-phase plan mapping	Registration of 3 <sup>rd</sup> party /historic map overlays etc.	Archaeological investigation of landscapes
OBJECT SIZE	1 - 2m, 0.2 – 0.5m		
PRECISION	Typical output:1:500 scale	Selection of appropriate grade of equipment to meet project data requirements	
ASSOCIATED TOOLS/SKILLS	CAD/GIS/co-ordinate transformation and adjustment. EDM survey, field drawing		Appropriate thematic knowledge to make selection decisions at capture, data presentation and map production
	Digital cartography, hachured plan production.	GIS design and management	

There are a number of Global Navigation Satellite Systems (GNSS). The name of the U.S. Global Positioning System (GPS, in operation since June 26, 1993) is now commonly used as a term used to describe the process of position finding using a constellation of satellites in orbit around the earth. Other systems include the Russian GLObal NAVigation Satellite System (GLONASS), the Chinese Beidou system and the European Space agency GALILEO system. GPS is the primary survey method for defining global, regional and national co-ordinate systems. For many purposes GPS is an everyday tool used to make maps, set-out roads, record utility assets, measure volumes and levels in quarries, as well as a multitude of other tasks, including those undertaken in historic landscape investigation and recording.

The intention of this chapter is to provide sufficient information to inform survey users as to whether this might be a suitable tool for them, and illustrate the ways in which GPS might be used. It is now the primary technique for many survey tasks undertaken on a wide variety of projects with differing survey requirements, ranging from recording wide areas of surviving archaeological landscapes at topographic scales, to mapping the position of individual stones in large-scale surveys of individual sites.

**GPS IS A DIRECT TECHNIQUE**

GPS can be used to resolve the position of points in 3 ways:

- LOCAL            To know where any point is on a site, usually in three dimensions.
- RELATIVE        To resolve where points are in relation to each other, so that a plan can be made of the site.
- ABSOLUTE        Where the site is in relation to a map on a national or international co-ordinate system.

Mapping with GPS requires the selection of information from the landscape: GPS is simply a method of deriving the co-ordinate position of selected points on the Earth's surface.

**HOW GLOBAL POSITIONING SYSTEMS WORK**

GPS provides free, 24 hour, all weather, global coverage from a constellation of about 30 satellites. The satellites orbit the earth approximately every 12 hours at an altitude of 20,200 kilometres and broadcast continuous navigation signals (Fig 6.1). With the proper equipment, users can receive these signals to obtain an instantaneous, real-time position to within c10m, anywhere in the world. In its simplest form GPS works by measuring the distance between GPS satellites and the user's receiver. The distance is computed by measuring the time interval between the transmission of the satellite signal and its reception by the receiver. As the relative positions of the satellites are known, simultaneous measurements to more than four satellites enable the unknown position of the receiver to be computed by trilateration. This calculation requires an exact knowledge of the position of the satellites in space and very accurate timing, as the distance is derived from the time it takes for a signal to travel from the satellite to the receiver. GPS receivers need to receive a signal from at least four satellites, three to perform the triangulation and the fourth to synchronise timing. The accuracy of any point recorded by a GPS receiver is governed by a number of factors relating to the environment, equipment used, surveying techniques and, if the GPS position is to be related to background mapping, the co-ordinate transformation used. There are three key concepts (see below) which need to be understood by anyone wishing to make use of GPS for surveying. Although the science and mathematics of GPS is complex, the survey practitioner only needs to know enough of the basics to permit making informed decisions about:

- ♦ the type of equipment to use for a particular task
- ♦ how that equipment can be used efficiently for any given surveying task
- ♦ ensuring that any data derived from GPS can be used to produce accurate surveys, maps, plans or records to suit the particular project or task.

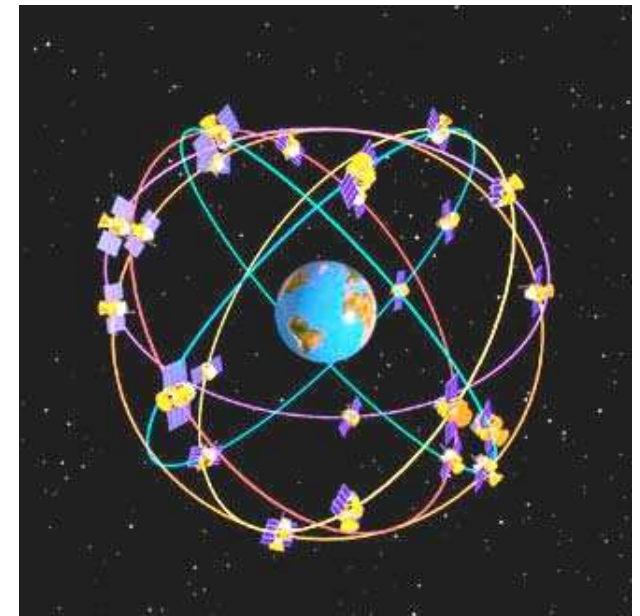

**Fig 6.1 THE GPS CONSTELLATION**  
The satellites are in orbit at 20,200km. The constellation is designed to provide 24 hour global coverage. Positions on the surface of the earth are derived from analysis of the radio signal broadcast by the satellites and the geometry of the constellation at any given moment.

**KEY CONCEPT 1  
GLOBAL CO-ORDINATE  
GEOMETRY**

To get GPS data that is going to fit with other mapped data it must be correctly projected on to an agreed co-ordinate system.

**KEY CONCEPT 2  
GPS ACCURACY**

Because of the range of GPS measurement systems available it is important to recognise the constraints on GPS performance and the kind of accuracy to expect.

**KEY CONCEPT 3  
WORKFLOW**

GPS precision and data utility is different depending on the choice of processing method: 'real-time' or 'post process'. It is more precise if it is adjusted after fieldwork to take account of the measurement environment variables than at the time of capture.

**KEY CONCEPT 1:  
GLOBAL CO-ORDINATE GEOMETRY**

To get co-ordinates that fit our local topography, the geometry of both the satellite constellation and the curvature of the Earth need to be resolved. The former is provided by the satellite data. The latter requires precise knowledge of the shape of the earth, which is approximated using a geodetic model.

The earth's shape can be described as an oblate spheroid. Mapping this shape uses ellipsoids, geoids, projections and co-ordinate systems. The processing of GPS data to agree with local maps needs the user to be aware of these critical parameters:

**ELLIPSOID**

An ellipsoid (see Fig 6.2) is a mathematical surface which approximates the curved shape of the Earth's surface. Historically, accurately measuring the size and shape of the Earth has been difficult and as a result several ellipsoids were defined in the past, which were often chosen to fit best on a regional rather than a global scale. To address local mapping requirements, many countries have devised national map projections and referencing systems. Traditionally, cartographers used lines of latitude and longitude, derived from celestial observations, to map the surface of the globe. It is only since the advent of man-made satellites that it has been possible to accurately measure distances on truly international scales and enable a precise global co-ordinate system. Geodesists therefore have to determine the relationship between the old and

new co-ordinate systems in use. This relationship is solved mathematically using a transformation.

**GEOID**

The geoid describes the shape formed by mean sea level over the earth and its imagined extension under the land areas (blue on Fig 6.2, datum). This provides a world wide datum to which heights above mean sea level can be related. Historically, survey heights in different countries have been related to an agreed national datum to which all heights on national mapping agency maps and benchmarks are related. The datum is based on mean sea level tidal observations at a national or regionally agreed point, and is used to determine 'mean sea level' for the purposes of a standard height reference. Heights derived from GPS data have to be transformed to agree with the local or national datum using a geoid model. GPS equipment will supply height information, but without adjustment for the geoid and reference to a datum it is almost worthless: failure to apply the correct datum can result in serious errors in your GPS height values.

As a new GPS user, it is very easy to set up a GPS receiver and produce data. Without some understanding of how the data relates to the required projective geometry it will be hard to know which co-ordinate system should be used and which transformations will be necessary to relate the data to a local map or datum.

**ELLIPSOID**

The ellipsoid is a mathematical surface that approximates the surface of the Earth.

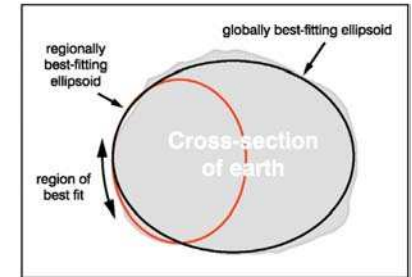

**WGS84**

The ellipsoid (red), geoid (blue) and topographic surfaces (brown) in relation to WGS84

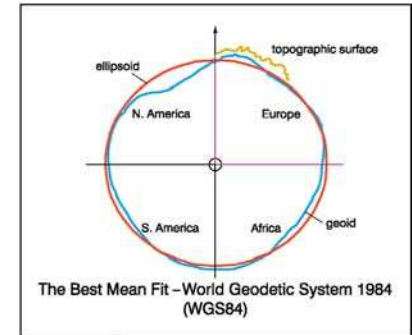

**DATUM**

The difference between heights referenced to the ellipsoid, and a local datum.

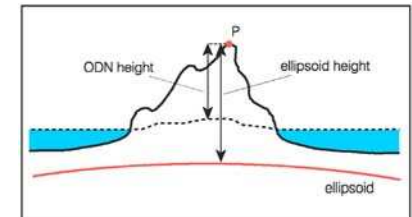

**PROJECTION**

The difference between the flat plane of a map and the curved surface of the earth.

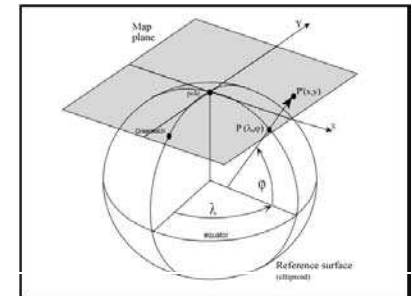

Fig 6.2  
THE BASIS OF GLOBAL CO-ORDINATE GEOMETRY

# KEY CONCEPT: GLOBAL CO-ORDINATE GEOMETRY

## PROJECTION

A projection is necessary to allow the curved surface of Earth to be represented as a flat plane. Universal Transverse Mercator (UTM) is the internationally agreed mapping projection (Fig 6.3). Globally UTM has 60 zones, each one using an origin point derived from the intersection of the zonal longitude line and the equator. In turn, regional and national grid schemes use local origin points derived from the UTM.

## CO-ORDINATE SYSTEMS

Co-ordinates describe positions on the projected surface provided by the projection. To use GPS data for mapping, it is necessary to understand the different co-ordinate systems used by the local or national mapping agency.

## THE GPS CO-ORDINATE SYSTEM: WGS84

Whilst we think of a grid reference in relation to a co-ordinate system on a map, such as a National Grid on national agency maps, a position derived from GPS data is related to a global co-ordinate system known as the World Geodetic System 1984 (WGS84). WGS84 is an internationally agreed, global reference framework of co-ordinates in which a point can be defined anywhere in the world. Co-ordinates in this system are usually expressed as geographic co-ordinates (latitude, longitude and ellipsoid height). Whilst most people will be familiar with latitude and longitude, ellipsoid height may be more confusing. This NOT the same as a height above sea level as shown on a map and exists only mathematically. Fig 6.2 (WGS84) shows that when survey measurements are taken on the topographic surface (brown), heights are usually related to mean sea level (blue). Heights derived directly from GPS relate to the theoretical mathematical surface of the ellipsoid (red). In order for GPS ellipsoid heights to be related to mean sea level another theoretical datum, the difference between the two surfaces, needs to be defined as a geoid model.

A high-accuracy version of WGS84, known as ITRS (International Terrestrial Reference System) has been created in a number of versions since 1989, and this is principally used for geodetic work. There is a major problem with trying to use a global co-ordinate system for land surveying in any particular country or region. This is that the continents are constantly in motion with respect to each other, at rates of up to 12 centimetres per year. There are in reality no fixed points on Earth.

For this reason, various local terrestrial reference systems have been developed for different continents.

## ETRS89

The European Terrestrial Reference System 1989 (ETRS89) is an example of a regional GPS co-ordinate system. It has been officially adopted as a standard co-ordinate system for precise GPS surveying by most national mapping agencies in Europe. ETRS89 is based on ITRS, and was originally devised as a highly accurate global co-ordinate system with a better 'fit' than WGS84, but because of tectonic movements it required constant adjustment to work globally. It was therefore agreed to use it as a regional co-ordinate system tied to the European continent (but divorced from the rest of the globe) on the basis of its condition in 1989, so it is a system fixed in time. It is hence steadily diverging from the WGS84 co-ordinate system. In 2000, the difference between the ITRS co-ordinates of a point and the ETRS89 co-ordinates was around 25cm, and increasing by about 2.5 cm per year. The relationship between ITRS and ETRS89 is precisely defined at any point in time by a simple transformation of the co-ordinates, published by the International Earth Rotation Service.

In summary, it is important to recognise that these global co-ordinate systems have implications for using GPS for relating objects or sites to national agency survey maps. If the accuracy requirement of a survey is 1m or larger, then WGS84 co-ordinates can be accepted and converted to a

local national grid if necessary. If the requirement for accuracy is higher than 1m, and you are surveying in a territory with an agreed regional GPS co-ordinate system (e.g. ETRS89 in Europe), then co-ordinates should be derived using this. If the regional GPS co-ordinate system is used you can effectively ignore the effects of continental drift: to a high degree of accuracy, the co-ordinates of a survey station thus revised stay fixed, as long as there is no local movement of the survey station.

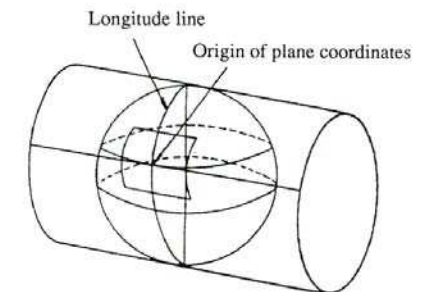
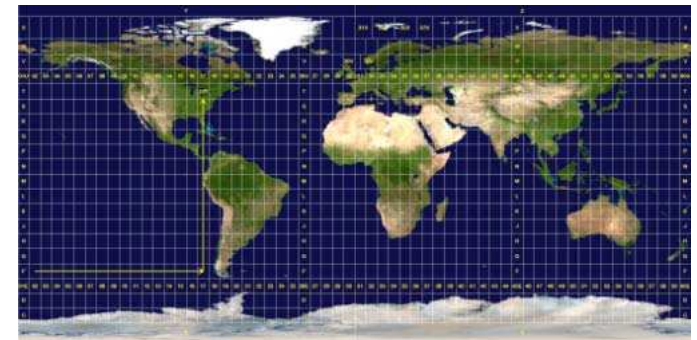

Fig 6.3 Projection of a curved surface onto a plane using the Universal Transverse Mercator (UTM) projection. By international agreement the UTM is divided into zones (top). This projection is the most commonly used as it does the best job of dealing with the problem of mapping a spheroid onto a plane.

## NATIONAL GPS NETWORKS

Many national mapping agencies have set up base stations to enhance the performance of GPS mapping. These base stations relay grid co-ordinate adjustment data to the same GPS receiving equipment used for survey and can increase both the local and relative precision of recorded GPS data immensely.

A National GPS Network consists of GPS stations of two types:

### ACTIVE STATIONS

A network of fixed GPS receivers can be permanently installed at locations throughout a national or regional territory. They will be distributed so that any location in the territory should be within 100km of an active station, with most major urban areas are covered by more than one. Data from these stations is continually monitored and processed by the national mapping agency and is available for each station through various broadcast media, often via a dedicated website. They are termed 'active' because they are continuously operating and their inclusion in a GPS survey does not require the user to physically occupy the control point. In the UK the precise position of these is known in relation to the ETRS89 co-ordinate system. The establishment of these stations and the availability of data via the internet has had a massive impact on the ease of use of GPS for high accuracy surveying.

### PASSIVE STATIONS

This is a network of ground-marks which have been established in accessible locations, the position of each of which has been established in relation to the ETRS89 co-ordinate system. The main difference between a passive network and an active station network is that a passive station has to be occupied by the user's own GPS receiver. Passive station co-ordinates, station descriptions and photographs can usually be freely downloaded from the national mapping agency's website.

Using data from the active stations or the co-ordinates of the passive stations means that newly surveyed points can be accurately related to a national GPS network.

## KEY CONCEPT 2: GPS ACCURACY

GPS accuracy has three distinct aspects: relative, map and absolute. These can be characterised as follows;

- ◆ relative accuracy – the accuracy of points in the survey in relation to each other
- ◆ map accuracy – how well the positions of these points agree with their plotted positions on a map
- ◆ absolute accuracy – the correspondence between the measured co-ordinates of a point and the repeatably verifiable co-ordinates of the point on the surface of the Earth using a common positional reference frame.

Referencing features to a national co-ordinate framework ensures that they are accurately recorded for integration into GIS data-sets and archaeological records. This is particularly relevant in open landscapes, where obtaining accurate national or regional grid references is otherwise difficult.

GPS has meant that the accurate positioning of surveys and monuments onto maps and into geo-referenced databases is relatively straightforward. Survey-grade GPS equipment (see GPS EQUIPMENT) and software can combine relative accuracy and map accuracy in the same package. In order to position things such as sites, finds, trenches, and landscape surveys accurately, the field recorder needs to know which type of GPS set will achieve the relevant map accuracy required. The relationship between relative accuracy and map accuracy is illustrated in Fig 6.4. The shape and size of the field is correct, but it is displaced relative to its position as shown on the map.

The surveyor has to recognise that the plan positions of features recorded by GPS may not agree with the positions of the same features on a large-scale national agency map.

This may simply be because the type of GPS receiver is navigation-grade and cannot be accurate to better than c. 10m (see GPS EQUIPMENT). Alternatively, it may be because the map is not as accurate as the GPS derived position. Understanding the provenance of the map data is important: in urban areas large-scale mapping is more common and its accuracy will have been tested, but rural zones may have sparsely updated small-scale coverage.

It is possible to undertake surveys using survey-grade equipment (see GPS EQUIPMENT) and use a 'best fit' approach to match the position of the survey with older large-scale mapping. This solution retains the relative accuracy of the survey although the positional accuracy is compromised by the local map detail used. It is a pragmatic method for fitting small surveys into existing map-based records.

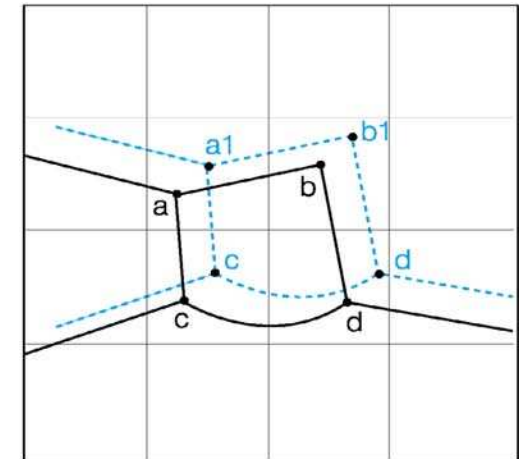

Fig 6.4 RELATIVE & MAP ACCURACY. The four plotted points have good relative accuracy but poor map accuracy.

## KEY CONCEPT: WORKFLOW

### DGPS

Differential GPS (DGPS) is a technique for improving the precision of the measurements by using additional GPS data. This can be provided by a network of points maintained for this purpose or by using more than one receiver.

### REQUIRED ADDITIONAL DATA FOR DGPS

- ◆ Geo-stationary satellites e.g. WAAS/ EGNOS
- ◆ One (or more) receiver(s) with relayed data from a network of fixed stations e.g. Active station data, Marine DGPS
- ◆ Multiple receivers without relayed data - Local adjustment using the distances between the base station receivers for correction

### DIFFERENTIAL GPS ACCURACY

Differential positioning is achieved by measuring relative positions of two or more receivers. One is a static reference (base) station while the other is a rover receiver, which moves relative to it - both receivers are collecting GPS data during the survey.

At the start of the survey the base station position is fixed by assigning it a nominal or known co-ordinate. The base station is left in place for the duration of the survey and continually gathers data to refine its position. The base station relays this updated data to the rover whilst simultaneously logging data about the rover's position relative to it. The precision of the measured data set is improved by the combination of the two possible trilaterations. On completion of field work, the position of the base station can be further refined (Fig 6.7) using published satellite position data to resolve base-station position and then apply the necessary correction to the logged rover positions.

Two of the main error sources of GPS are discrepancies between the predicted and actual positions of the satellites

(which affects the distance) and delays in the transmitted signal due to the atmospheric interference (which affects the timing). With both the base and rover receivers theoretically tracking the same GPS signals simultaneously and calculating the difference between the 'known' and computed positions, these errors can be limited. This technique is based on the assumption that the variance in the signals received at the base station will also be present at the rover, but it should be noted that as the distance between the two increases this assumption becomes less valid.

There are two methods of using differential GPS: post-process and real-time. With post-processing, a base station sits at a fixed point and collects GPS data, while a rover unit moves around collecting data for a short period at each point of interest in the survey area. At the end of the survey all the data is processed in a computer and each of the survey points is accurately fixed relative to the base station. With real-time surveying (see KEY CONCEPT 3) the base station uses the GPS position computations backwards; using its known position to calculate the difference between the actual time taken by the GPS signal to travel from the satellite and what it calculates the time interval should be. It then continuously transmits this error correction factor to the roving unit (Fig 6.5).

Real-time correction services are available which enable a user to operate a single receiver. Sub-metre accuracy is achievable through correction signals broadcast from either ground-based transmitters or geo-stationary satellites. These correction services are typically

available from a public marine navigation service or from commercial sources.

### KEY CONCEPT 3: WORKFLOW

To make decisions about appropriate equipment and workflow the method of data capture should be considered: the two routes are 'post process' and 'real-time'.

### POST-PROCESS

Post-processing is undertaken after the raw GPS data has been captured to improve accuracy. Post-processing equipment is cheaper than the equivalent real-time systems

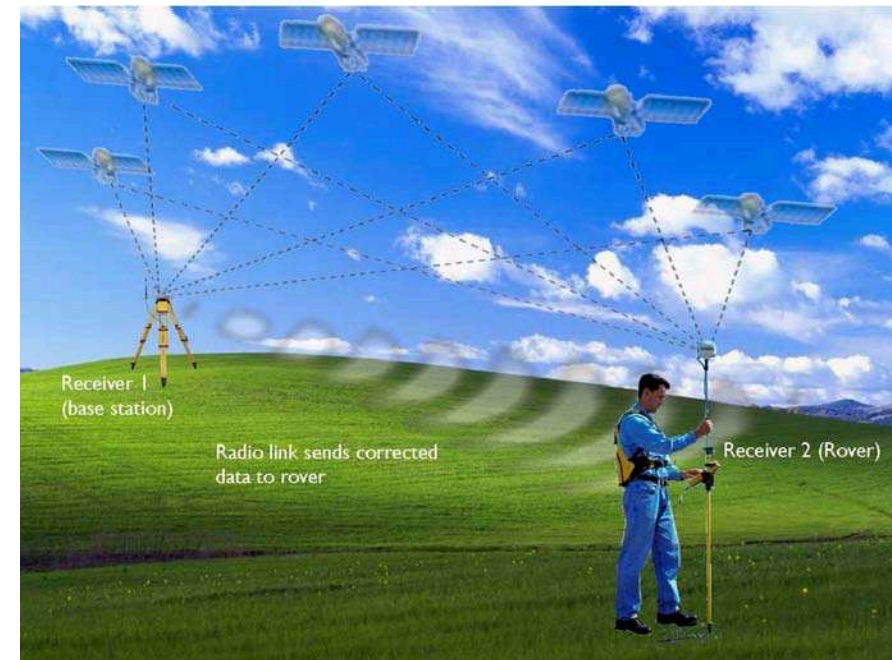

Fig 6.5 DIFFERENTIAL GPS METHOD

DGPS uses a static base-station and a radio relay to update the precision of the logged rover position.

for a similar level of accuracy. Post-processing often requires proprietary software depending on the field equipment used; most manufacturers provide training courses if required.

## REAL-TIME (Verification feedback)

If positional data is required in real-time, an appropriate field-computing platform will be needed. At the lowest level, a hand-held, navigation-grade GPS receiver is a real-time system as it allows the user to view or store a co-ordinated position in the field. The horizontal accuracy of such units is unlikely to be any better than c.10m. Some more sophisticated hand-held GPS sets do allow the storage of GPS data which may then be post-processed on a computer, which can increase the level of accuracy.

The major advantage of real-time surveying is that the user will have verification feedback and can be confident in the GPS positions before leaving the site. If the data-logging device has a display, such as a pen computer or Personal Digital Assistant (PDA), the resulting co-ordinates can be instantly plotted and visualised as they are recorded. This could have digital maps and plans pre-loaded into it so that revision and updating can be instant. The position of features that are not visible on the ground, but which are known from historic maps, aerial photographs LIDAR. or geophysical surveys can also be set out on the ground. Data-logging devices may also accept input from other survey equipment to complete surveys where GPS is not an appropriate capture method; tapes, theodolite, reflectorless distance lasers, etc. Much office time can be saved as the survey can be visualised in the field. The disadvantage of real-time surveys is that the equipment required is generally more expensive than systems which use post-processing techniques, but this has to be balanced against operational requirements.

## GPS EQUIPMENT

There are three kinds GPS equipment

- ◆ Navigation grade

- ◆ Mapping grade
- ◆ Survey grade

Each type has different levels of accuracy. The difference between them centres around the different signal processing techniques they use to determine position. It is important to remember that the receivers are not the only piece of equipment necessary; there will be a requirement for tripods, poles, batteries, chargers, data-loggers, radio links, computers etc, especially for mapping and survey-grade GPS. Without these peripherals, the receiver will be of no use.

## NAVIGATION GRADE (HAND-HELD) GPS

Navigation grade GPS receivers are used by walkers, sailors and for in-car and aircraft navigation. They are of only very limited use as surveying instruments, though they still can be useful as a means of positioning sites or finds. As they use a coarser element of the signal they can often work better under woodland canopy than survey grade GPS. This type of equipment will not generally provide horizontal positional accuracy to better than c.10m. In remote areas this is certainly better than nothing, but attempting to plan a site or record features relative to one another at this low level of accuracy is not recommended.

## MAPPING GRADE (GIS DATA COLLECTION) GPS

These are lightweight systems that can be used for surveying and mapping purposes where accuracy of between 0.5m and 5m is acceptable. This type of unit comprises either a backpack mounted receiver linked to a datalogger/portable computer, or a hand-held unit, which combines the receiver and logger into a single unit. Mapping grade hand-held GPS units are distinguished from navigation grade ones by their data logging capacity and additional functionality linked to data acquisition. They often allow a pre-loaded map background to be viewed concurrently with the acquired data and permit feature and attribute coding to be attached to surveyed points, producing plans

with information attached to component features (see SURVEYING WITH GPS). This type of receiver can achieve accuracy in the 2m to 5m range on its own, but with the use of differential correction or by post-processing, this can

Navigation grade GPS.  
Low cost leisure utility unit. Precision in the c.10m order is possible.



Mapping grade GPS. The outfit is usually based around a single rover unit. These units are designed for small scale mapping and asset geo-referencing for GIS. Precision in the c10m order is readily available.



Survey grade GPS.  
The outfit consists of Base station, rover and the radio link between them. The rover receiver is often mounted on a pole for precise positioning of detail points. Sub metre precision is easily achieved. Used differentially, centimetre precision is available.



Fig 6.6  
THE THREE TYPES OF GPS EQUIPMENT

be improved to 0.5m. Differential correction data can be obtained from radio beacons and geostationary satellites, such as the Wide Area Augmentation System (WAAS) or European Geostationary Navigation Overlay Service (EGNOS). Post-processing can be carried out using data from active stations in a national GPS network, with just a few seconds of data recorded at each point. This type of system is ideal for mapping at scales of up to 1:2500 and recording associated details for database and GIS systems. Because they also use the coarser element of the GPS signal, they work better under woodland canopy than survey grade GPS.

## SURVEY GRADE GPS

Survey grade equipment is the most accurate and usually the most expensive GPS option (see Table MATCHING EQUIPMENT TO THE TASK). It is the only type of GPS which can produce survey quality data at the centimetric level of relative horizontal accuracy. There are two principle methods of collecting data with survey grade GPS, static and real-time kinematic (RTK). All survey grade systems use a differential approach (DGPS) to survey processing.

## SURVEY GRADE GPS TECHNIQUES: STATIC SURVEYING

Static surveying is the simplest form of GPS survey using this equipment. This post-process technique requires data to be simultaneously collected at two (or more) locations and used later in computations to determine the baseline

(or baselines) between the receivers. The time required to collect sufficient data for statistically robust adjustment varies from ten minutes to several hours. Data must be acquired from a minimum of 4 satellites, with the amount of data (and hence time) increasing with baseline length and required accuracy. Static surveying is the technique used to tie local site surveys to a national grid using a national GPS network. Baselines from a survey site to the nearest active stations are routinely up to or over 100km in length and require base-station data to be collected for several hours, preferably on more than one day, to achieve the best results.

## SURVEY GRADE GPS TECHNIQUES: REAL-TIME KINEMATIC (RTK) GPS

The receiver at the base station transmits GPS correction data to one or more roving units in real-time via a telemetry link, a UHF radio or mobile 'phone. This technique provides an accurate and very flexible way of surveying on open sites. The rover can be set to record continuously, or by short occupations of the surveyed points; the length of occupation can be varied depending on the accuracy required, and is normally between a few seconds and a few minutes (see Methods that increase the usefulness of GPS). These systems achieve a relative accuracy of c.1cm between the base station and rover over a range of up to 8km. Because of the high accuracy, flexibility of recording at large and small scales and the time saved by not having to post-process data, this has shown itself to be a practical and cost efficient method for GPS

survey.

## MAKING CHOICES

Making informed decisions about appropriate surveying technology can be difficult. Simply getting hold of equipment rarely solves mapping problems: clarity in informed selection is the most valuable resource in surveying! The table MATCHING EQUIPMENT TO THE TASK provides a summary of some of the considerations to be taken into account when making choices about using GPS for a recording project. The best policy to adopt is to think backwards, that is to define the end product first and then determine the appropriate survey strategy to achieve this. Despite its flexibility, GPS requires a sizeable investment in terms of field equipment, software and training - it may be cheaper to hire equipment rather than to buy it if it is not going to be used often. Depending on the size of the area to be mapped and the scale at which it is to be presented a direct technique such as GPS may not be the best approach; indirect techniques of topographic mapping like aerial photogrammetry and LIDAR may capture more information for less effort.

For example, the survey requirement for an open site may call for an end product comprising a detailed survey at 1:500 scale and an eight-figure grid reference for a record system. Alternate methods to GPS could be EDM, field drawing, aerial photogrammetry and LIDAR. However, if only the centre-point of the site is needed to locate it on local national agency mapping (at say 1:10,000 scale) then

## MATCHING EQUIPMENT TO THE TASK

TASK/ END PRODUCT	MAP ACCURACY REQUIRED	EQUIPMENT
Locations to be identified by a grid reference and plotted on a 1:10000 base map.	c. 10m	Navigation grade GPS (hand-held). Approximate cost at 2003: £100 - £300
Objects and monuments to be plotted against an Ordnance Survey 1:2500 map, or production of plan of a similar scale.	c. 1m	Mapping grade GPS. Accuracy can be improved for free-standing surveys by <i>Differential</i> (DGPS) survey technique and post-processing. Approximate cost at 2003: £1000 - £8000
Accurate, measured survey plans at 1:1000 and larger scales, three-dimensional data.	c. 0.10m	Survey grade GPS Data available in real-time or post processed. c. 0.01m relative accuracy can be achieved for free-standing surveys using <i>Differential</i> survey techniques. Approximate cost at 2003: £18000 - £22000



navigation grade GPS will achieve this (at that scale a point can only be plotted to c. 10m anyway). If the survey requirement is more complex and needs other products such as:

- ◆ a detailed 1:100 scale survey of the site
- ◆ a 1:2,500 scale survey of its contemporary and historical landscape
- ◆ landscape survey to be fitted onto the local digital map base, with possible long term further research potential using e.g. GIS
- ◆ establishment of permanent survey control to aid excavation, point sampling sites for waterlogging monitoring, geophysical survey, fieldwalking etc.
- ◆ creation of a three-dimensional model of the monument.

then consistency of relative accuracy and map accuracy need to go hand in hand. To achieve both types of accuracy using other direct techniques like EDM or an indirect one like photogrammetry is potentially be more costly. Using a navigation grade GPS could not provide either relative accuracy or map accuracy over a large area, with each point potentially being 10m in error. Mapping grade GPS could not achieve the accuracy required for the detailed survey and establishment of control for further work, and therefore survey grade GPS offers the most appropriate method to address the problem, as it can meet most of the survey requirement well as being faster than EDM survey. The suitability of survey grade GPS for the job would be completely different if the subject was under tree cover or required 'stone by stone' recording at a different scale (e.g. 1:20 or 1:50): it is a question of balancing the technique with the information need.

It is important to recognise that GPS is a flexible technique that can be successfully applied to many survey problems. Survey grade GPS is now commonly used by land surveyors, cartographers and many other professions and

organisations who require accurate positioning of features, objects or assets on a plan.

## SOME BASIC SURVEYING PROCEDURES

Using GPS in the field is relatively simple. As a means of providing fast and accurate location of points on the Earth's surface, when used correctly and under the right conditions, it has no rival.

## RECONNAISSANCE

The terrain should be assessed to see if satellite reception is clear of interference from trees, buildings, cliff faces etc. Where differential GPS techniques are to be used, a safe and secure location for the base station should be found. If surveying in real time, then there should be no obstructions to radio communications between the base and rover receivers. This can be a problem in very hilly terrain and urban areas, and in these locations it may be necessary to fix more than one base station, a repeater station, or to use a mobile 'phone. If there is a block of woodland, GPS might be used to fix control stations around the edge from which to run EDM traverses under the trees; this method can also be used to good effect in complexes of high walls and buildings such as castles and monastic sites. For sites where geophysical survey and excavation require grid-based recording, GPS can be used as a rapid way of setting out the grid on the ground, regardless of visible sight-lines. GPS is also an ideal tool for surveying in inter-tidal environments (Chapman et al 2001).

Most GPS processing software includes functions that use the broadcast ephemeris or almanac (orbital information) data that contains predictions of satellite positions. This can be of great benefit when working on sites at high latitudes when satellite availability can be a problem.

The amount of sky visible, how many satellites are available and their relative positions all affect the quality of the data and resultant accuracy. One of the advantages of real-time survey grade equipment is that the operator can see

immediately whether the data is acceptable. Post-processing does not offer real-time verification feedback and re-survey may be necessary if accuracy has been compromised during capture.

## GEO-REFERENCING

GPS is useful for providing positioning data in a consistent geo-spatial reference system; depending on the level of equipment used, objects and features can be geo-referenced in real-time and/or be directly surveyed into national agency mapping..

## INCREASING THE UTILITY OF GPS

The effectiveness of survey grade GPS in the field can be improved by:

### MULTIPLE ROVERS

More than one rover receiver can be used with a base station. Thus, larger volumes of data can be collected. It is often efficient to have two rovers working on a site, receiving correction data from a single base station. This can be used as either a post-processed technique or in real time.

### GROUND MODELLING

Large quantities of 3D data can be collected using survey grade equipment by walking or driving over a site. This data can be used to generate a Digital Terrain Model (DTM) which can then be used to generate contours or be analysed in a GIS, enabling calculation of e.g. volumes, slope, drainage and view-shed analysis.

### GIS & INVENTORY DATA CAPTURE

GPS is useful as a capture device for attributed geo-spatial information suitable for inclusion in a GIS. The attribute tags used should match those in the GIS database and can be filled in by the surveyor at the point of capture. GPS is a useful tool for populating an existing map, adding inventory data to a database and verifying features identified from indirect techniques like aerial photogrammetry and LIDAR.

## FEATURE CODING

The raw output from GPS is only a series of 3-dimensional points. These points must be combined with 'feature coding' to denote lines, line types, line weights and colours. Feature coding software is normally installed on the data logger or pen computer and processed through CAD, where information can be further be organised by layer. This permits the GPS data to be converted into a meaningful plan of the site. It is rare that GPS alone can be used to record every aspect of a complicated site, and it should be standard operating procedure to take the plot back into the field for final checking and possible additional survey.

## LIMITS OF GPS

Despite GPS offering many advantages to the surveyor, there are a number of factors to be considered.

- ◆ GPS will not work indoors or under trees.
- ◆ GPS receivers have to be able to 'see' a minimum of four satellites to work, five to work in real-time kinematic mode.
- ◆ Signals may be affected near high-voltage power lines and transmitters and these are best avoided if possible. Problems may also be encountered close to airfields and military establishments.
- ◆ Multipath errors occur when the signals received by the antenna have not arrived by a direct path but have been reflected off other surfaces such as buildings or foliage. Multipath errors cannot be corrected by differential GPS. The antenna, receiver and post-processing software can detect and attempt to resolve multipath, but errors may still be present in the survey data. If multipath is a serious problem on a site, it is probable that GPS is not the most appropriate technique for undertaking the survey.
- ◆ GPS satellites operate in 20,200-km orbits, in six orbital planes. Because of the way in which these orbits are aligned, satellite availability is always biased towards

the equator. Thus in the higher latitudes, obstructions towards the equator, such as steep slopes or buildings, can be a problem.

- ◆ Real-time kinematic GPS often uses VHF/UHF telemetry to transmit the correction data between the base station and rover. Local broadcast controls may restrict the power and frequency of radio transmissions and this limits operational range to about 8km. Obstructions such as hills or buildings can also adversely affect radio communications. However real-time surveying systems do allow the collection of data for post-processing if the radio link is lost; this means that the survey can carry on until the link is re-established. This can be a common occurrence in very hilly areas, but is easily overcome by moving the base station to a more suitable location or using repeater stations. Other delivery methods are available such as the use of mobile 'phones'; however this incurs higher running costs.

## Fig 6.7 TYPICAL DGPS DATA PROCESSING

Field capture involves establishing a base station and logging its position for the duration of the survey whilst recording the rover position. Processing the collected data begins with the transformation and adjustment to agree with the known network positions. Illustrations show (top) the unknown position of the base station in relation to the network. The rover positions as recorded during the survey (centre), and the equipment in use (bottom).

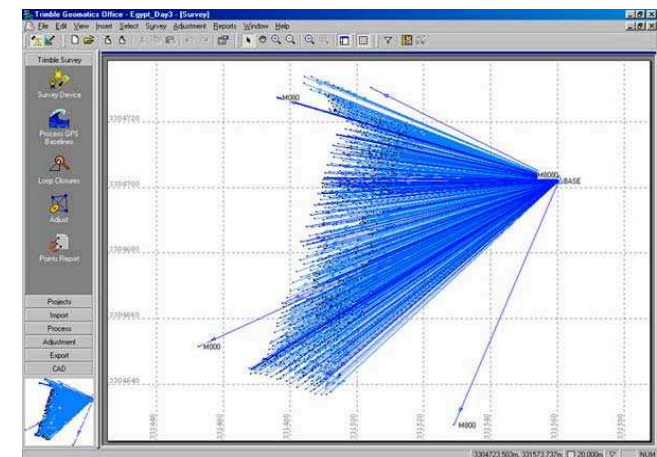
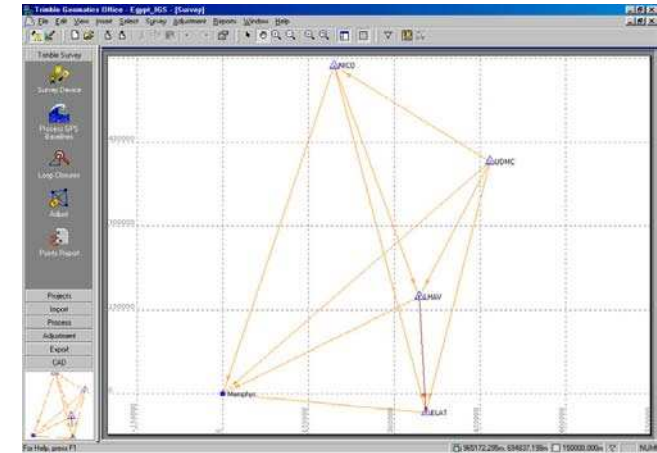



Base station receiver mounted on levelled tripod with repeater radio, antenna, and power supply.



Rover unit: on a detail pole with radio link to base station, data-logger (also on right), power supply and receiver.



The data-logger gives current information on the condition of the constellation as well as the coding options needed to select points for mapping.

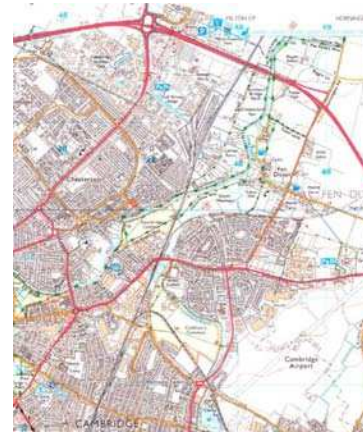

Digital map tile of background terrain for updating, amending or verifying. Depending on the data logging method it is possible to plot new points onto existing mapping in real time. This is a typical procedure in GIS and asset mapping.



Base station radio relay unit: for DGPS this is essential, the unit relays the base station position to the rover to form the base line for the trilateration of each measured point.

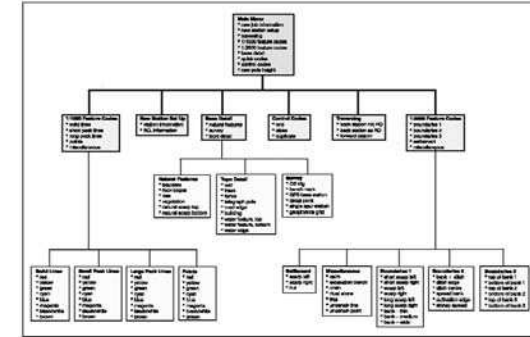

Feature code list. This will be either on the data logger or in the live CAD file as layers.



Tribrach, the base station can be re-occupied by an EDM or prism target if required: the standard traversing tribrach allows re-occupation with out re-levelling etc.



Station markers and detail pegs; if a feature needs to be pegged out for chain and offset survey from GPS tie points.



Rover unit: on a detail pole with power supply) to base station logger, power supply and receiver.

# GLOSSARY OF GPS TERMS

Active stations	A network of continuously operating, high quality GPS receivers located throughout a region usually managed by a national mapping agency. In e.g. the UK, GPS RINEX data is downloaded hourly from each station and released onto the national GPS network web site.		system throughout Europe. It is a more precise definition of the WGS84 GPS co-ordinate system, fixed in 1989.		passive stations. This network allows users of GPS to carry out positioning in the precise ETRS89 co-ordinate system.
Almanac	A set of parameters included in the GPS satellite navigation message that a receiver uses to predict the approximate location of a satellite. The almanac contains information about all of the satellites in the constellation.	Ephemeris	A description of the path of a celestial body indexed by time. The navigation message from each GPS satellite includes a predicted ephemeris for the orbit of that satellite for the current hour. Precise ephemeris data files can be downloaded from the US National Geodetic website ( <a href="http://www.ngs.noaa.gov/">http://www.ngs.noaa.gov/</a> ). The precise ephemeris contains the recorded positions and is available after one day for the NGS Rapid Orbits version or eight days for the NGS Precise Orbits version.	National Grid	A national standard co-ordinate system for mapping.
Co-ordinate converter	A software utility that transforms co-ordinates from one co-ordinate system into another.			Passive stations	Publicly accessible survey stations located throughout a country or region. The locations and precise co-ordinates of these stations are known and can usually be acquired through the relevant national mapping agency.
Co-ordinate system	A pre-defined framework onto which coordinates can be related.	Geoid	A mathematical model of the level surface which is closest to mean sea level over the oceans. The surface is continued under the land and acts as a fundamental reference surface for height measurement.	Projection:	Method of describing a curved surface on a plane.
Differential GPS (DGPS)	A technique for increasing the accuracy of GPS derived positions by using additional data from a reference GPS receiver at a known position.	Geo-reference	Co-ordinate reference on a regional or national co-ordinate system.	Transformation	A co-ordinate transformation enables a user to convert from one co-ordinate system to another. For example, in the UK from ETRS89 to OSGB36 using the OSTN02 transformation.
Ellipsoid	A three-dimensional geometric figure used to approximate the shape of the earth.	GIS	Geographic Information System	WGS84	World Geodetic System 1984. The standard co-ordinate system for GPS data throughout the world.
ETRS89	The European Terrestrial Reference System 1989. This is the standard precise GPS co-ordinate	National GPS Network	For example in the UK: A network of reference stations throughout Great Britain maintained by the Ordnance Survey. It consists of some 32 active stations and 900		

Brown, A 1987 *Fieldwork for Archaeologists and Local Historians*. London: Batsford

Chapman, H P Fletcher, W G and Thomas, G 2001 'Quantifying the effects of erosion on the archaeology of intertidal environments: a new approach and its implications for their management' *Conservation and Management of Archaeological Sites*, **4**, 233-40

Chapman, H P, and de Noort, R 2001 'High-resolution wetland prospection, using GPS and GIS: landscape studies at Sutton Common (South Yorkshire), and Meare village east (Somerset). *Journal of Archaeological Science*, **28**, 365-75

Dickinson, G C 1969 *Maps and Air Photographs* London: Arnold

Hoffman-Wellenhof, B, Lichtenegger, H, and Collins, J 1997 *GPS Theory and Practice* (4th edition) Springer-Verlag

Iliffe, C 2000 *Datums and Map Projections*. Whittles Publishing.

Leicke, A 1995 *GPS Satellite Surveying* (2nd edition) John Wiley and Sons

Pearson, F 1990 *Map projections: theory and applications* CRC Press

Pearson, T 1998 *Yeavinger Bell hillfort*. English Heritage Archaeological Investigation Report Series AI/24/1998

RCHME 1999 *Recording Archaeological Field Monuments: a descriptive specification*. Swindon: RCHME

RICS, forthcoming *Use of GPS in Land Surveying*

Steers, J A 1965 *An introduction to the study of map projections* London: University of London Press

Sickle, J V (1996) *GPS for Land Surveyors*, Ann Arbor Press, Inc, Chelsea, Michigan.

## ACKNOWLEDGEMENTS

The text in this section is derived from 'Where on Earth are we? The global positioning system in archaeological field survey' by Bernard Thomason and Stewart Ainsworth, with contributions by Mark Bowden. English Heritage 2003 Product code 50788